

# SOLAR INSTALLATIONS

## SOLAR COLLECTORS, TANKS AND SYSTEMS FOR INDIVIDUAL AND COLLECTIVE INSTALLATIONS

### Solar collectors:

- DH 200 - DH 200SL - CH 250 and CH 250SL: flat glass collectors with an overall surface area of 2 or 2.5 m<sup>2</sup>, and thin frame for SL versions
- POWER 15: tubular collectors (15 vacuum tubes) with an overall surface area of 2.1 m<sup>2</sup>

### For solar installations:

- Domestic: with BSL/BESL, QUADRO solar tanks or STMO thermosiphon systems
- Collective: with B, FWS solar tanks, RSB storage tanks, PS/PSB buffer tanks



DH 200/DH 200SL  
CH 250/CH 250SL



POWER 15



QUADRO

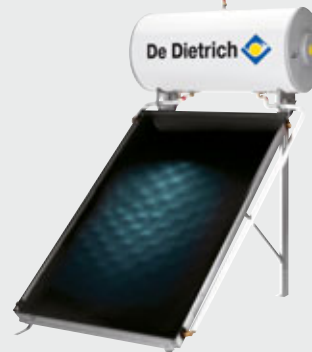

STMO



B, RSB, PS, PSB



Domestic hot water  
+ heating back-up



Renewable energy



Solar energy



KEY MARK:  
- DH 200: 078/000215  
- DH 200SL: 078/000264  
- CH 250: 078/000216  
- CH 250SL: 078/000259  
- POWER 15: 011/7S412R



DH 200 SL ] 14/16-2181  
CH 250 SL ]

All of the equipment shown in this document is used for making individual or collective solar installations, from the simplest to the most complex, in line with the DHW and/or heating requirements.

De Dietrich offers comprehensive solutions combining solar collectors and tanks, as well as all the accessories such as solar stations, solar regulators, installation and connection kits, etc.

EXPORT

**De Dietrich**  
SUSTAINABLE COMFORT®



# CONTENTS

2	GENERAL INFORMATION	14	INSTALLING SOLAR COLLECTORS ON A ROOF
3	CHOICE OF COLLECTOR TYPE CHOICE OF INSTALLATION TYPE	16	DOMESTIC SOLAR INSTALLATIONS FOR DHW PRODUCTION
4	DH 200SL AND CH 250SL FLAT SOLAR COLLECTORS	26	SOLAR ACCESSORIES FOR DOMESTIC SOLAR INSTALLATIONS
6	DH 200 AND CH 250 FLAT SOLAR COLLECTORS	30	COLLECTIVE SOLAR INSTALLATIONS FOR DHW PRODUCTION
8	POWER 15 TUBULAR SOLAR COLLECTORS	48	SOLAR ACCESSORIES FOR COLLECTIVE SOLAR INSTALLATIONS
10	POSITIONING OF THE COLLECTOR FIELD INSTALLING SOLAR COLLECTORS ON THE GROUND OR A TERRACE	60	SIZING A COLLECTIVE SOLAR INSTALLATION

## GENERAL INFORMATION

### SOLAR ENERGY INPUT

Every day our planet receives a large solar energy flux. The power of this radiation at a given point is dependent on the surface temperature of the Sun, on the distance between the Earth and Sun, the weather conditions and atmospheric diffusion (dispersion, reflection and absorption phenomena). In both summer and winter the power of the solar radiation reaching a surface perpendicular to this radiation is approximately 1000 W/m<sup>2</sup>. This figure will then vary depending on the incidence angle on the receiver, the sunlight intensity and duration.

In Greece the annual average quantity of solar energy received is around 1600 to 1900 kWh/m<sup>2</sup> per year. Hence it is highly advantageous to use this free, non-polluting energy to produce domestic hot water, heat pools and contribute to heating buildings.

Quantity of annual solar energy received in kWh/m<sup>2</sup> per day

Zone 1	2.8 to 4.4
Zone 2	4.4 to 5.2
Zone 3	5.2 to 6
Zone 4 (French Overseas Depts& Territories, Canary Islands)	> 6

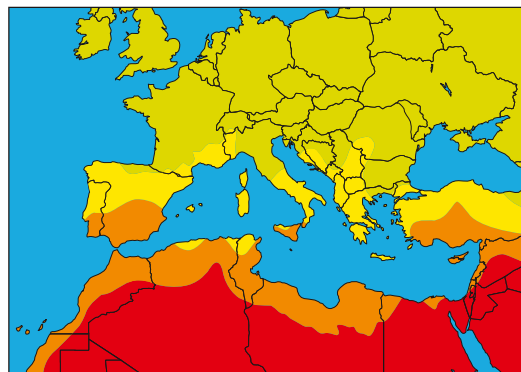

Europe solar map

### SAVING ON FOSSIL FUEL AND PROTECTING THE ENVIRONMENT

- it is the most profitable hot water production technology, compared to purchasing a conventional water heater. Purchasing a solar hot water production system represents both an investment, and energy and final savings,
- the solution provides independence from the electrical network for hot water production,
- using solar energy means safeguarding the environment. This technology economises 1 to 1.5 tonnes of CO<sub>2</sub> per year and per family,

- opting for solar energy means freeing yourself from rising costs of traditional energies,
- finally, with De Dietrich solar hot water production systems, you can be assured of a mature, innovative and perfectly reliable solution.

### SIZING AN INSTALLATION

Estimating the daily domestic hot water consumption helps pre-size and check the possible positioning:

- solar collector field,
- solar tank volume.

Depending on the surface areas and volumes found, it is possible to opt for a system:

- with built-in heat exchanger,
- with plate heat exchanger.

In this way it is possible to pre-cost any installation. In every case, this is only about pre-sizing the main components. Accurate sizing with a profitability calculation is required in every scenario.

Sizing assistance software used to analyse all the aspects of the approach can be consulted:

- SOLO ([www.cstb.fr](http://www.cstb.fr) or [www.tecsol.fr](http://www.tecsol.fr)) for example.

De Dietrich Thermique also offers sizing assistance and recommendations in its software DIEMATOOLS. In addition, based on the information used for pre-sizing, De Dietrich offers the following via its HQ technical assistance:

- checking the feasibility of the planned installation,
- checking its as-planned hydraulic diagram,
- simulating the potential savings.

In addition, our DIEMATEC software can be used to create hydraulic diagrams in AutoCAD, with a "De Dietrich" library.

# CHOICE OF COLLECTOR TYPE

The graph opposite provides an overview of the efficiencies of the various types of solar collector, depending on the desired collector outlet temperatures:

- for the solar carpet (non-glass black PUR) use for heating pools or ponds, the maximum permissible collector outlet temperature is 40 °C.
- DH 200.../CH 250... flat glass collectors, which have an efficiency of more than 50 % for use at  $\Delta T = 20$  to 50 K, are ideal for use in the field of heating domestic water or central heating. Use at less than 50 % efficiency, i.e. at higher temperatures, would only pointlessly increase the necessary solar surface areas.
- POWER tubular collectors, whose efficiency remains above 50 % with a  $\Delta T$  of 80 K should be favoured for high-temperature applications, which can be found in industrial, food or solar air conditioning processes. They also have

applications in scenarios of poor exposure or reduced / insufficient installation areas where requirements are high, with a view to increasing the part of the installation covered by solar energy.

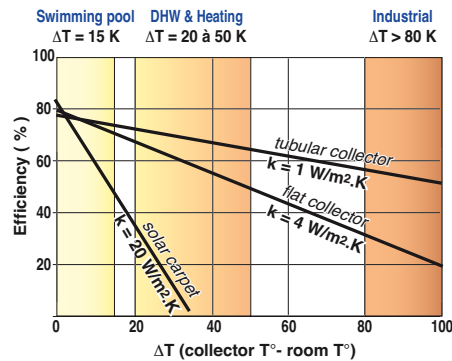

# CHOICE OF INSTALLATION TYPE

## MODULAR SYSTEMS

There are two technologies enabling a solar installation to be managed:

- **Pressurised systems** with an expansion vessel to absorb heat-transporting fluid expansion, and the possible effects of stagnation in case of overheating.

Pressurised systems may be set up with all types of collectors and buildings (with no height constraint up to 60 m), but must be correctly sized to prevent overheating. These types of installation are simple and with no constraints: the heat-transporting fluid must be suitable for the installation's climate conditions in terms of frost resistance (under no circumstances should water be used).

These systems should only be adopted for installations with a continuous and permanent energy demand (e.g. hotel, home).

- **Self-draining systems** without an expansion vessel which only irrigate the collector fields when the solar energy is available and the storage tanks need to be heated.

They require suitable collectors and care when setting up the solar circuit: the collectors and the entire solar circuit must be drainable by gravity. The solar pump must overcome the pressure drops in the circuit and the installation's water column height (building height limited to + or - 40 m).

When inactive, the collectors are drained, which prevents overheating of the storage tank and makes them suitable for uses with highly fluctuating requirements.

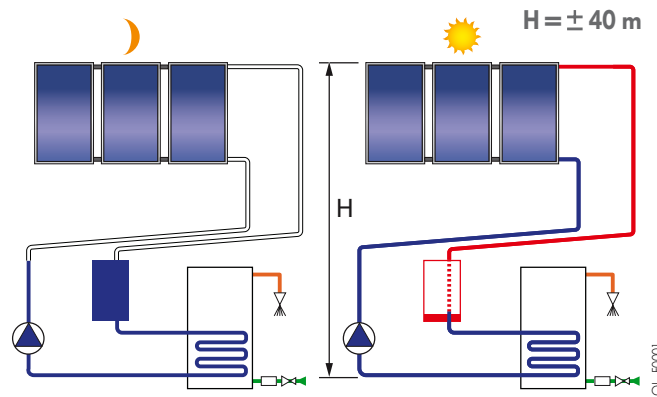
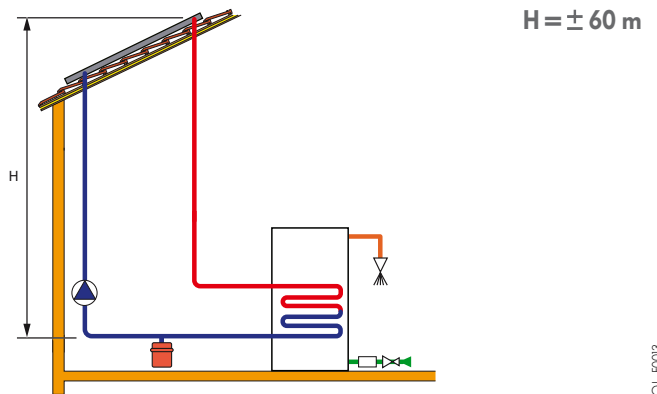

## MONOBLOC OR THERMOSIPHON SYSTEMS

**Thermosiphon systems** have the advantage of being autonomous, and operate on their own with no other energy (excluding the back-up). They can be installed on sloping or terrace roofs. Comprising a storage tank and 1 or 2 collectors, they can provide the DHW requirements of a house. Set-up on a terrace is simple, though more complicated on a sloping roof, whose timbers will need to support the weight of the tank filled with water.

These systems can only be used in regions free from the risk of frost.

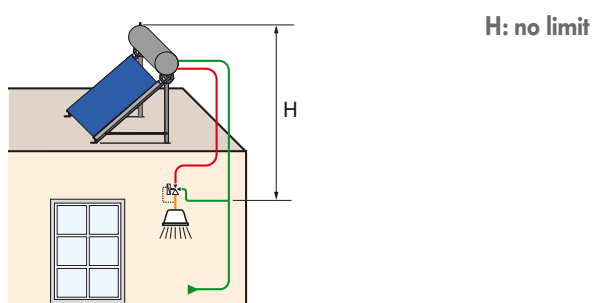

8960219B

SOL\_F003

SOL\_F001

SOL\_F010

# DH 200SL AND CH 250SL FLAT SOLAR COLLECTORS

For DH 200SL/CH 250SL flat collectors, serial connection is possible up to 10 collectors for installation on a roof or terrace. For installing more than 10 collectors, the hydraulic connection must be divided into branches connected in parallel in a

Tichelmann loop, with each branch having the same number of collectors. The fields will need to be balanced using balancing valves.

## USES

All hot water production applications at temperatures  $< 80\text{ }^{\circ}\text{C}$  with more or less regular requirements in case of pressurised systems, or irregular requirements in the case of self-draining systems, with heat-transporting fluid only. In self-draining configuration, the collector field must be installed level, with no gradient on either side, to enable the heat exchangers to be drained. Some residual fluid will remain the manifold tube whenever circulation is stopped.

## PACKAGE LIST

- 1 DH 200SL flat collector: package ER719
- 1 CH 250SL flat collector: package ER743

The collectors are delivered in an upright individual package on a pallet. The pallets delivered must be stored (vertically or horizontally) until the collectors are installed, in a dry, sun-free and aerated place with no risk of condensation.

## DESCRIPTION

Flat glass high-efficiency solar collector for installation of up to 10 serial collectors, comprising:

- an anthracite grey coloured frame made from aluminium profiles with a fastening groove around the perimeter, and anticorrosion-treated aluminium base sheet,
- a translucent glass safety window, thickness 3.2 mm and translucency  $> 91\%$ ,
- a flat aluminium absorber with selective coating and drainable sinusoidal heat exchanger connected to 2  $\varnothing$  16 mm manifold tubes for serial connection to 4 points in a bank,
- rear and lateral rock wool insulation, thickness 20 mm.

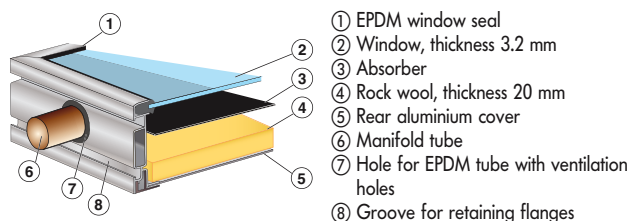

- ① EPDM window seal
- ② Window, thickness 3.2 mm
- ③ Absorber
- ④ Rock wool, thickness 20 mm
- ⑤ Rear aluminium cover
- ⑥ Manifold tube
- ⑦ Hole for EPDM tube with ventilation holes
- ⑧ Groove for retaining flanges

## MAIN DIMENSIONS (mm)

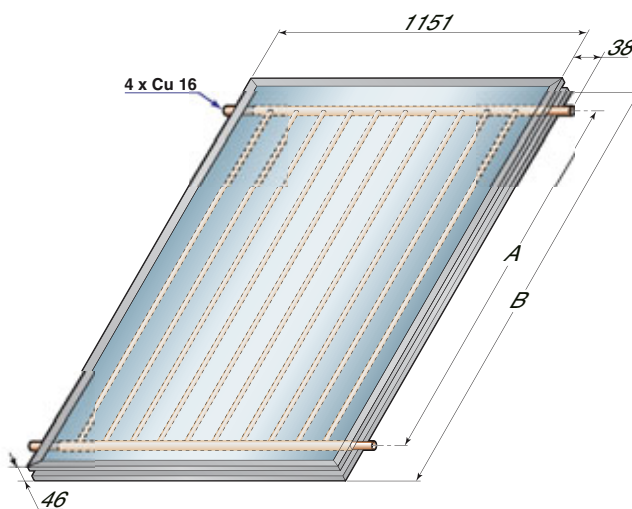

	A (mm)	B (mm)
DH 200SL	1 610	1 757
CH 250SL	2 044	2 191

## TECHNICAL SPECIFICATIONS

Collector	Type	DH 200SL	CH 250SL
Overall surface area $A_G$	$\text{m}^2$	2.02	2.52
Inlet surface area $A_a$	$\text{m}^2$	1.92	2.40
Absorber area $A_A$	$\text{m}^2$	1.88	2.35
Fluid capacity	L	1.1	1.2
Recommended flow rate	$\text{L/h.m}^2$	30	30
Max. operating temperature	$^{\circ}\text{C}$	180	180
Stagnation temperature	$^{\circ}\text{C}$	212	212
Operating pressure	bar	2.5	2.5
Max. operating pressure	bar	10	10
Optical efficiency $\eta_{0A}$	%	0.732	0.740
Transfer loss coefficient $a_1$	$\text{W/m}^2.\text{K}$	3.860	3.915
Transfer loss coefficient $a_2$	$\text{W/m}^2.\text{K}^2$	0.017	0.013
Incidence angle factor $K_{\theta}$ for $50\text{ }^{\circ}\text{C}$	%	0.95	0.95
Net weight	kg	27	31

### Efficiency curve

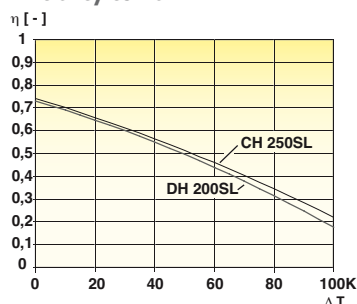

### Pressure drop curve

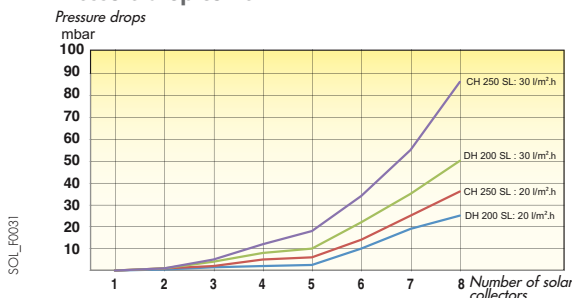

## HYDRAULIC CONNECTION ACCESSORIES FOR DH 200SL AND CH 250SL COLLECTORS

### ⇒ With quick-release connectors



#### Hydraulic connection kit for 2 collectors (O-ring connectors) - Packages ER726

Comprises:

- the 2 insulated hoses, length 1 m, with flat seal connectors,
- 1 collector outlet tee with sensor tube and manual vent,
- 1 collector inlet elbow,
- 2 plugs,
- 2 connectors between collectors,
- 1 collector sensor,
- retaining pins and seals.

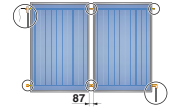

DH200\_Q0007

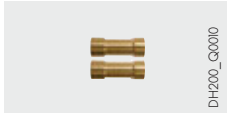

#### Hydraulic connection set between 2 collectors (O-ring connectors) - Package ER727

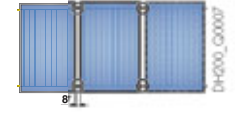

DH200\_Q0007

### ⇒ With screw-in connectors



#### Bicone connectors kit for hydraulic connection for 2 collectors - Package ER720

Comprises:

- 1 collector outlet tee with sensor tube and manual vent,
- 1 collector inlet elbow,
- 2 plugs,
- 2 bicone connectors between collectors,
- seals.

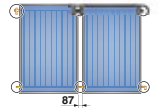

DH200\_Q0007



#### Hydraulic connection set between 2 collectors (bicone connectors) - Package ER721

#### Set of 2 insulated hoses (flat seal connectors) - Package ER247

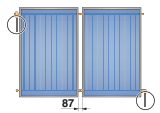

DH200\_Q0007

### Note

The components of the "Hydraulic connection kit for 2 sensors - Package ER720" are also available in sets of several units:

- set of 10 collector outlet tees: package ER723
- set of 10 collector inlet elbows: package ER722
- set of 20 plugs: package ER724
- set of 20 bicone connectors between collectors: package ER725

## COLLECTOR CIRCUIT INSTALLATION

The collectors are installed in sets known as banks.

In a bank, the hydraulic connections between collectors are in parallel, to limit pressure drops.

To ensure uniform irrigation of DH 200SL or CH 250SL collectors, we recommend limiting each bank to 8 units if connecting on the same side, or 10 units for a diagonal connection. For optimum collector efficiency, fields of 5 to 6 collectors are preferable.

Opposite are some hydraulic coupling configurations which prevent the most frequent design errors.

### 1 bank

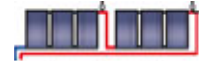

### n banks of x collectors with flow rate adjustment valve

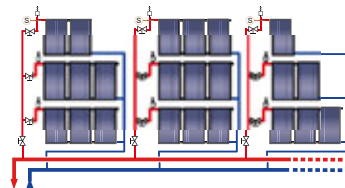

### 3 banks of collectors in parallel with Tichelmann loop\*

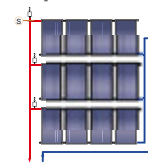

\* min. Tichelmann loop diameter: DN 28

SCOL\_F0021

### Balancing collector circuits

One frequently observed cause between the thermal performances of a solar system measured on-site and those predicted by calculations is often attributed to incorrect balancing of the collector field. Connecting the banks in parallel with a Tichelmann loop ensures pre-balancing, and limits pressure drops if the banks are uniform.

**Additional rule to respect:** the ratio of the manifold tube internal  $\varnothing$  to the collector pipe internal  $\varnothing$  must be between 1.6 and 3.3.

**Note:** if a Tichelmann loop cannot be installed, you need to install flow rate adjustment valves able to easily balance each collector field and/or the collectors on the different banks. There are self-regulating adjustment valves which avoid manual adjustments of each bank.

## PACKAGE LIST DEPENDING ON THE NUMBER OF COLLECTORS TO BE INSTALLED

Hydraulic connection accessories	Package no.	Number of DH 200SL and CH 250SL collectors installed in 1 row									
		1	2	3	4	5	6	7	8	9	10
⇒ For systems with quick-release connectors:											
- Hydraulic connection kit for 2 collectors (O-ring quick-release connectors)	ER726	1	1	1	1	1	1	1	1	1	1
- Hydraulic connection kit between 2 collectors in vertical series (O-ring quick-release connectors)	ER727	-	-	1	2	3	4	5	6	7	8
⇒ For systems with screw-in connectors:											
- Hydraulic connection kit for 2 collectors (bicone connectors)	ER720	1	1	1	1	1	1	1	1	1	1
- Hydraulic connection set between 2 collectors (bicone connectors)	ER721	-	-	1	2	3	4	5	6	7	8
- Set of 3/4" hydraulic connection hoses	ER247	1	1	1	1	1	1	1	1	1	1

# DH 200 AND CH 250 FLAT SOLAR COLLECTORS

For DH 200/CH 250 flat collectors, serial connection is possible up to 10 collectors for installation on a roof or terrace. For installing more than 10 collectors, the hydraulic connection must be divided into branches connected in parallel in a

Tichelmann loop, with each branch having the same number of collectors. The fields will need to be balanced using balancing valves.

## USES

All hot water production applications at temperatures  $< 80\text{ }^{\circ}\text{C}$  with more or less regular requirements in case of pressurised systems, or irregular requirements in the case of self-draining systems, with heat-transporting fluid only.  
In self-draining configuration, the collector field must be installed level, with no gradient on either side, to enable the heat exchangers to be drained. Some residual fluid will remain the manifold tube whenever circulation is stopped.

## PACKAGE LIST

- 1 DH 200 flat collector: package ER646
- 1 CH 250 flat collector: package ER647

The collectors are delivered in an upright individual package on a pallet (up to 8 collectors).  
The pallets delivered must be stored until the collectors are installed, in a dry, sun-free and aerated place with no risk of condensation.

## DESCRIPTION

- Flat glass high-efficiency solar collector for installation of up to 10 serial collectors, comprising:
- an anthracite grey coloured frame made from aluminium profiles with a fastening groove around the perimeter, and anticorrosion-treated aluminium base sheet,
  - a translucent glass safety window, thickness 3.2 mm and translucency  $> 91\%$ ,
  - a flat aluminium absorber with selective coating and drainable sinusoidal heat exchanger connected to 2  $\varnothing$  22 mm manifold tubes for serial connection to 4 points in a bank,
  - rear and lateral rock wool insulation, thickness 40 mm.

## MAIN DIMENSIONS (mm)

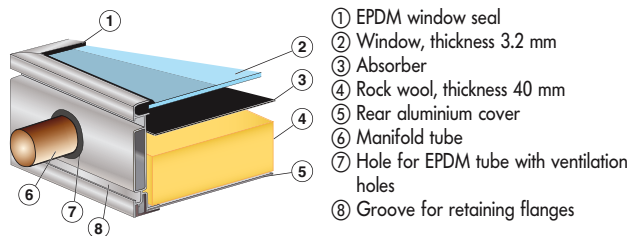
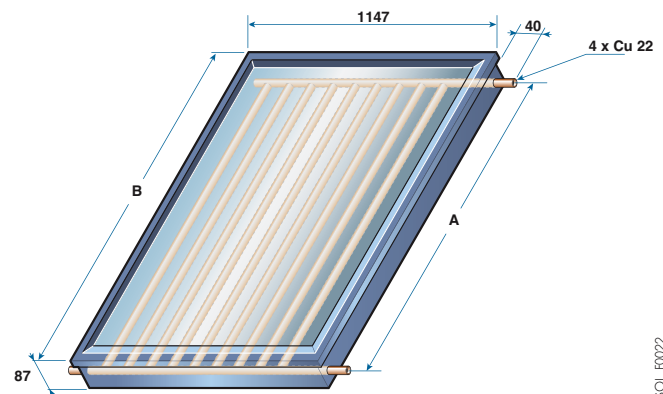

- 1 EPDM window seal
- 2 Window, thickness 3.2 mm
- 3 Absorber
- 4 Rock wool, thickness 40 mm
- 5 Rear aluminium cover
- 6 Manifold tube
- 7 Hole for EPDM tube with ventilation holes
- 8 Groove for retaining flanges

## TECHNICAL SPECIFICATIONS

Collector		DH 200	CH 250
Overall surface area $A_G$	$\text{m}^2$	2.01	2.51
Inlet surface area $A_a$	$\text{m}^2$	1.92	2.40
Absorber area $A_A$	$\text{m}^2$	1.87	2.35
Fluid capacity	L	1.5	1.7
Recommended flow rate	$\text{L/h.m}^2$	30	30
Max. operating temperature	$^{\circ}\text{C}$	180	180
Stagnation temperature	$^{\circ}\text{C}$	198	198
Operating pressure	bar	2.5	2.5
Max. operating pressure	bar	10	10
Optical efficiency $\eta_{0A}$	%	0.770	0.765
Transfer loss coefficient $\alpha_{1A}$	$\text{W/m}^2.\text{K}$	3.924	3.653
Transfer loss coefficient $\alpha_{2A}$	$\text{W/m}^2.\text{K}^2$	0.011	0.012
Incidence angle factor $K_{\theta}$ for $50\text{ }^{\circ}\text{C}$	%	0.91	0.91
Net weight	kg	37	44

## Efficiency curve

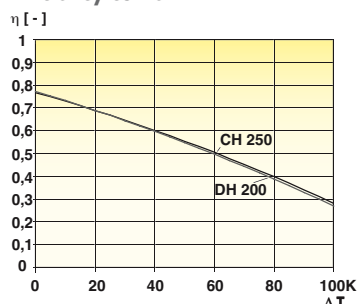

## Pressure drop curve

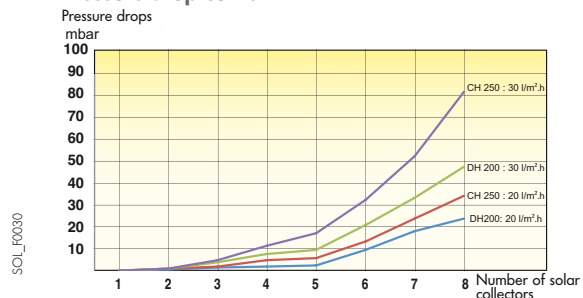

## HYDRAULIC CONNECTION ACCESSORIES FOR DH 200 AND CH 250 COLLECTORS

### With screw-in connectors

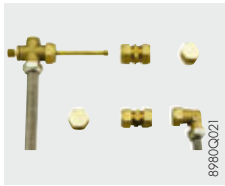

#### Hydraulic connection kit for 2 collectors (bicone connectors) - Package ER648

Comprises:

- 1 collector outlet elbow with sensor tube and manual vent,
- 1 collector inlet elbow,
- 2 plugs,
- 2 bicone connectors between collectors,
- 2 ribbed stainless steel hoses,
- seals.

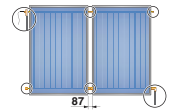

DH200\_Q0007

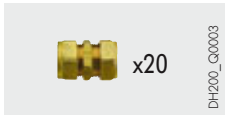

#### Set of 20 bicone connectors between 2 collectors - Package ER652

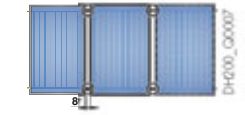

DH200\_Q0007



#### Set of 10 "collector inlet" elbow connectors, 3/4" - Package ER649



#### Set of 10 "collector outlet" elbow connectors, 3/4" - Package ER650

The connector comprises 1 collector sensor tube and the manual vent.

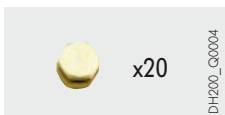

#### Set of 20 bicone plugs - Package ER651

## COLLECTOR CIRCUIT INSTALLATION

The collectors are installed in sets known as banks.

In a bank, the hydraulic connections between collectors are in parallel, to limit pressure drops.

To ensure uniform irrigation of DH 200 or CH 250 collectors, we recommend limiting each bank to 8 units if connecting on the same side, or 10 units for a diagonal connection. For optimum collector efficiency, fields of 5 to 6 collectors are preferable.

Opposite are some hydraulic coupling configurations which prevent the most frequent design errors.

### 1 bank

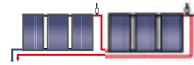

### n banks of x collectors with flow rate adjustment valve

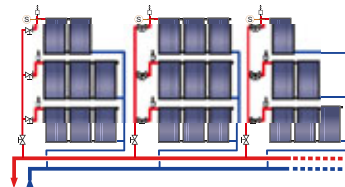

### 3 banks of collectors in parallel with Tichelmann loop\*

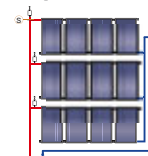

\* min. Tichelmann loop diameter: DN 28

SOI\_F0021

## Balancing collector circuits

One frequently observed cause between the thermal performances of a solar system measured on-site and those predicted by calculations is often attributed to incorrect balancing of the collector field. Connecting the banks in parallel with a Tichelmann loop ensures pre-balancing, and limits pressure drops if the banks are uniform.

**Additional rule to respect:** the ratio of the manifold tube internal  $\varnothing$  to the collector pipe internal  $\varnothing$  must be between 1.6 and 3.3.

**Note:** if a Tichelmann loop cannot be installed, you need to install flow rate adjustment valves able to easily balance each collector field and/or the collectors on the different banks. There are self-regulating adjustment valves which avoid manual adjustments of each bank.

## PACKAGE LIST DEPENDING ON THE NUMBER OF COLLECTORS TO BE INSTALLED

Hydraulic connection accessories	Package no.	Number of DH 200 and CH 250 collectors installed in 1 row									
		1	2	3	4	5	6	7	8	9	10
Hydraulic connection kit for 1 collector field (with 1 m ribbed stainless steel hoses)	ER648	1	1	1	1	1	1	1	1	1	1
Set of 20 bicone connectors between collectors	ER652	-	-	0.1	0.2	0.3	0.4	0.5	0.6	0.7	0.8
or											
Set of 10 "collector inlet" elbow connectors, 3/4"	ER649	0.1	0.1	0.1	0.1	0.1	0.1	0.1	0.1	0.1	0.1
Set of 10 "collector outlet" elbow connectors, 3/4" (collector sensor tube and manual vent.)	ER650	0.1	0.1	0.1	0.1	0.1	0.1	0.1	0.1	0.1	0.1
Set of 20 bicone plugs	ER651	0.1	0.1	0.1	0.1	0.1	0.1	0.1	0.1	0.1	0.1
Set of 20 bicone plugs between collectors	ER652	-	0.1	0.2	0.3	0.4	0.5	0.6	0.7	0.8	0.9

# POWER 15 TUBULAR SOLAR COLLECTORS

A high-efficiency tubular solar collector, comprising 15 concentric glass vacuum tubes, for roof or terrace juxtaposed vertical installation only, with up to 10 collectors in series.

## USES

All applications for DHW or heating water production, and industrial applications up to temperatures of 85 °C maximum, with high and continuous requirements. To be avoided for housing and occasional requirements.

## DESCRIPTION

The POWER 15 solar collector is equipped with 1 high-performance absorber comprising an internal glass tube with an external coating of 9 aluminium/nitrite-based selective layers. The glass tubes are strong and completely separated from the solar circuit comprising copper tubing, thereby enabling them to be replaced without draining the installation. The vacuum between the external and internal tubes ensures perfect insulation year-round. The parabolic surface reflector ensures optimum solar energy use, whatever the solar radiation angle. However an angle of at least 3° should be maintained to ensure good fluid circulation. The frame is made from aluminium and the built-in return tube enables POWER collectors to be connected on just 1 side (on the right or left), hence you need only make one trip to the roof.

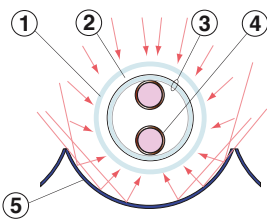

- ① External glass tube
- ② Vacuum insulation
- ③ Internal glass tube coated
  - externally with a 9-layer absorbing plate
  - internally with an aluminium plate
- ④ Copper tube containing the heat-transferring fluid
- ⑤ Parabolic reflector

We recommend limiting the banks to 8 collectors, to limit pressure drops in the collector fields.

## PACKAGE LIST

1 POWER 15 tubular collector: package EG391

**Note:** Several collectors can be delivered upright on 1 pallet.

## MAIN DIMENSIONS (mm AND INCHES)

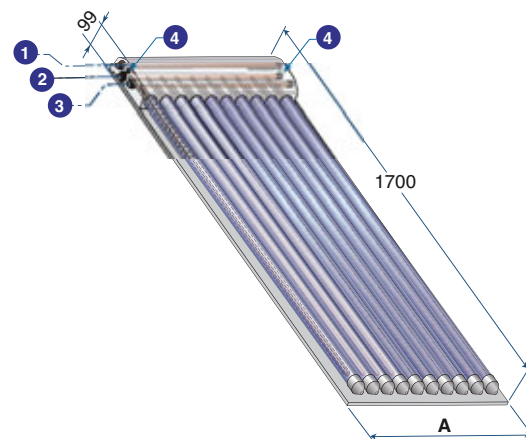

- ① G 3/4 collector inlet
- ② G 3/4 built-in return tube
- ③ G 3/4 collector outlet
- ④ Sensor tube

POWER	15
A (mm)	1 250

## TECHNICAL SPECIFICATIONS

Collector		POWER 15
Overall surface area $A_G$	$m^2$	2.13
Inlet surface area $A_a$	$m^2$	1.72
Absorber area $A_A$	$m^2$	2.48
Fluid capacity	L	2.0
Recommended flow rate per collector	L/h.m <sup>2</sup>	66
Max. operating temperature	°C	120
Stagnation temperature $t_{stg}$	°C	323
Operating pressure	bar	3
Max. operating pressure	bar	15
Optical efficiency $\eta_{0A}$	%	74
Transfer loss coefficient $a_{1A}$	W/m <sup>2</sup> .K	1.53
Transfer loss coefficient $a_{2A}$	W/m <sup>2</sup> .K <sup>2</sup>	0.0003
Incidence angle factor $\eta_{50}$	%	0.95
Net weight	kg	47

### ⇒ Efficiency curve (for irradiance $E_e = 800 \text{ W/m}^2$ )

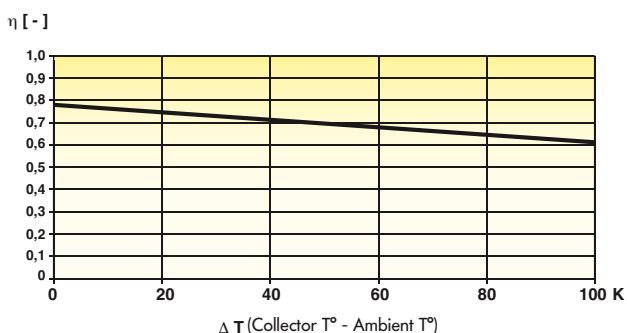

### ⇒ Pressure drop curve for collectors installed in a bank (vertical installation)

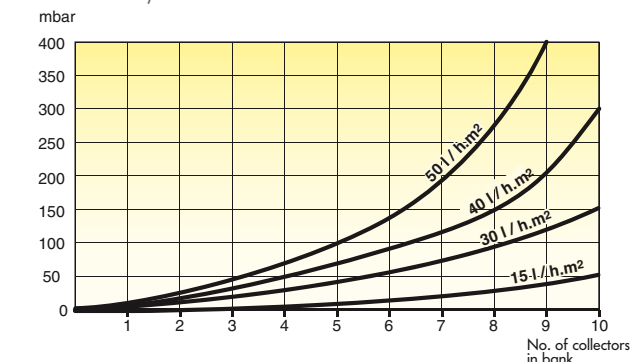

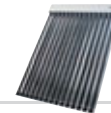

## HYDRAULIC CONNECTION ACCESSORIES FOR POWER 15 COLLECTORS



**Kit of 2 hoses + collector sensor - Package EG355**

For connecting a bank of collectors to the manifold tube.  
**Important:** fitting a vent at the high point of the collector field is obligatory (not supplied).

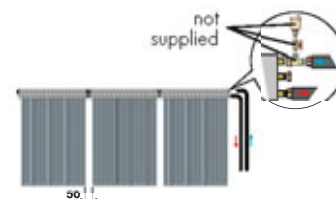

**Connection kit: end + plug - Package EG394**

Used for hydraulically connecting the collector on 1 side only (right or left) via the built-in return tube.

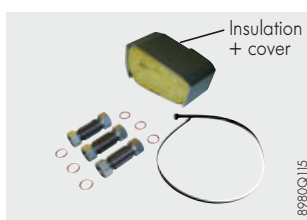
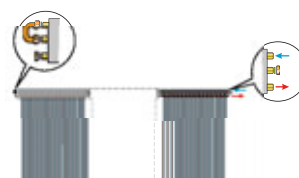

**Hydraulic connection kit between 2 collectors - Package EG393**

Used for hydraulic connections between 2 collectors. The delivery includes insulation + a cover for the connection.

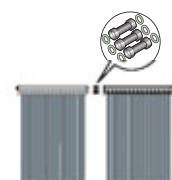

## COLLECTOR CIRCUIT INSTALLATION

The collectors are installed in sets known as banks.  
In a bank, the hydraulic connections between collectors are in parallel, to limit pressure drops.  
To ensure uniform irrigation of POWER 15 collectors, we recommend limiting each bank to 8 units if connecting on the same side, or 10 units for a diagonal connection. For optimum collector efficiency, fields of 5 to 6 collectors are preferable.

Opposite are some hydraulic coupling configurations which prevent the most frequent design errors.

**1 bank of 4 collectors**

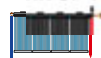

**n banks of 4 collectors with flow rate adjustment valve**

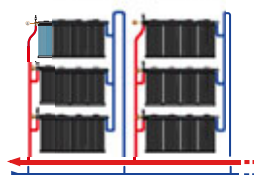

**3 banks of 4 collectors in parallel with Tichelmann loop\***



\* min. Tichelmann loop diameter: DN 28

POWER\_F0005A

POWER\_F0012

### Balancing collector circuits

One frequently observed cause between the thermal performances of a solar system measured on-site and those predicted by calculations is often attributed to incorrect balancing of the collector field. Connecting the banks in parallel with a Tichelmann loop ensures pre-balancing, and limits pressure drops if the banks are uniform.

**Additional rule to respect:** the ratio of the manifold tube internal  $\varnothing$  to the collector pipe internal  $\varnothing$  must be between 1.6 and 3.3.  
**Note:** if a Tichelmann loop cannot be installed, you need to install flow rate adjustment valves able to easily balance each collector field and/or the collectors on the different banks. There are self-regulating adjustment valves which avoid manual adjustments of each bank.

## PACKAGE LIST DEPENDING ON THE NUMBER OF COLLECTORS TO BE INSTALLED

Hydraulic connection accessories	Package no.	Number of POWER 15 collectors installed in 1 row									
		1	2	3	4	5	6	7	8	9	10
Kit of 2 hoses + collector sensor	EG355	1	1	1	1	1	1	1	1	1	1
End + plug connection kit	EG394	1	1	1	1	1	1	1	1	1	1
Hydraulic connection kit between 2 collectors	EG393	-	1	2	3	4	5	6	7	8	8

# POSITIONING THE COLLECTOR FIELD

- The collectors can be installed on a terrace or roof facing South-East to South-West in the Northern Hemisphere, which is unshaded in the winter with the Sun lower in the sky.
- The angle of the collectors must be between 15° and 85° to enable ventilation, with the optimum angle being between 30 and 60°.
- **The collectors** are designed for vertical installation. They can be installed with up to 10 collectors in series in a row (recommended: 8 collectors).

## Remarks:

### ⇒ Wall installation

We recommend shifting the bottom of the collectors from the wall to increase the solar input in summer.

### ⇒ Flat installation

Our collectors cannot be installed flat: a minimum angle of 15° for DH 200(SL) and CH 250(SL), and 3° for POWER, is required to ventilate the collector.

DH/CH

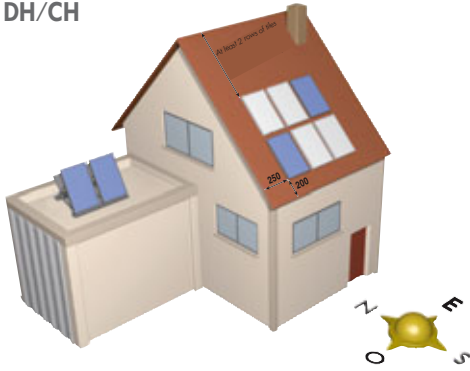

DE200\_F0001A

POWER 15

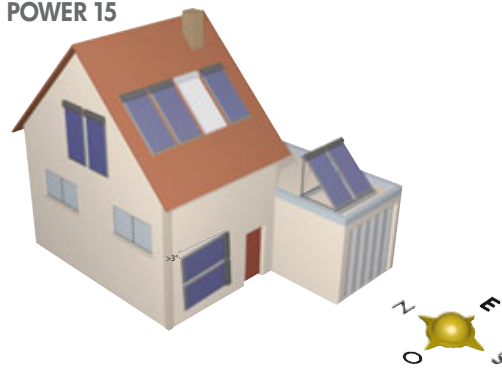

PROD\_F0003

# INSTALLING SOLAR COLLECTORS ON THE GROUND OR A TERRACE

## IZING THE COLLECTOR FIELD

### ⇒ Collector field width

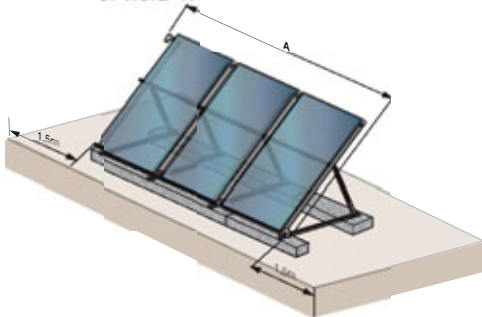

PROC\_F0027

Number of collectors in 1 battery		1	2	3	4	5	6	7	8	9	10
A (m)	DH 200 (SL)	1.3	2.5	3.7	4.8	6.0	7.2	8.4	9.6	10.8	12.0
	CH 250 (SL)	1.3	2.6	3.9	5.2	6.5	7.8	9.1	10.4	11.7	13.0
	POWER 15	1.3	2.6	3.9	5.2	6.5	7.8	9.1	10.4	11.7	13.0

### ⇒ Spacing between collector rows

If several parallel strips of collectors need to be installed, it is essential to maintain a minimum spacing between the rows to factor in the shadows cast.

The table opposite gives the minimum spacing (dimension x) between the rows. Three distinct solar energy uses (priority season) are specified:

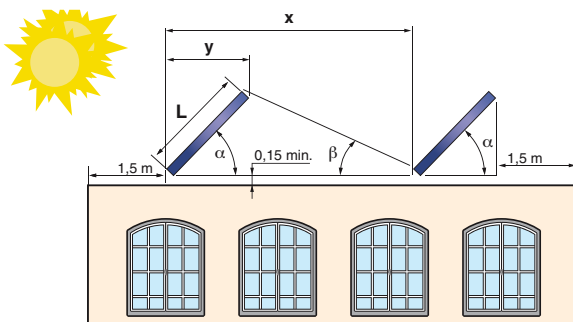

PROC\_F0009

Collector	Collector angle $\alpha$ ►	Favoured season			
		summer	summer/winter	winter	
<b>POWER 15</b> L = 1.7	Minimum spacing dimension x (m)	Sun height $20^\circ$	3.8	4.5	4.9
		$25^\circ$	3.3	3.8	4.0
		$30^\circ$	2.9	3.3	3.4
	Collector field depth y (m)		1.50	1.20	0.85
<b>DH 200</b> <b>DH 200SL</b> L = 1.8	Minimum spacing dimension x (m)	Sun height $20^\circ$	4.0	4.8	5.2
		$25^\circ$	3.5	4.0	4.2
		$30^\circ$	3.1	3.5	3.6
	Collector field depth y (m)		1.55	1.30	0.90
<b>CH 250</b> <b>CH 250SL</b> L = 2.2	Minimum spacing dimension x (m)	Sun height $20^\circ$	4.9	5.8	6.3
		$25^\circ$	4.3	4.9	5.2
		$30^\circ$	3.8	4.3	4.4
	Collector field depth y (m)		1.90	1.55	1.10

$\alpha$ : collector angle

$\beta$ : sun height

$$x = L \times \left( \cos \alpha + \frac{\sin \alpha}{\tan \beta} \right)$$

$$y = L \times \cos \alpha$$

Failure to comply with dimension x will cause shading of the next row, and accordingly reduce the active surface of the bank.

# INSTALLING SOLAR COLLECTORS ON THE GROUND OR A TERRACE

Collectors are installed on the ground or a terrace by means of tilting ground-mounted support feet, on which the collectors are installed.

The angle and orientation are free and independent from the position of the house, enabling optimum positioning of the collector field in relation to the sun.

## TERRACE INSTALLATION WITH SUPPORTS (MOUNTED VIA PROFILES ON SUPPORT FEET)

### Installation principle

The collectors are mounted on rails (profiles) which themselves are mounted on support feet. Each foot comprises pre-assembled profiles enabling the collectors to

be inclined at 5 different angles for DH 200 (SL) and CH 250 (SL) or 3 different angles for POWER 15.

→ Package list: see page 13

### ⇨ DH 200 (SL) and CH 250 (SL)

#### Mounting the support feet and profiles

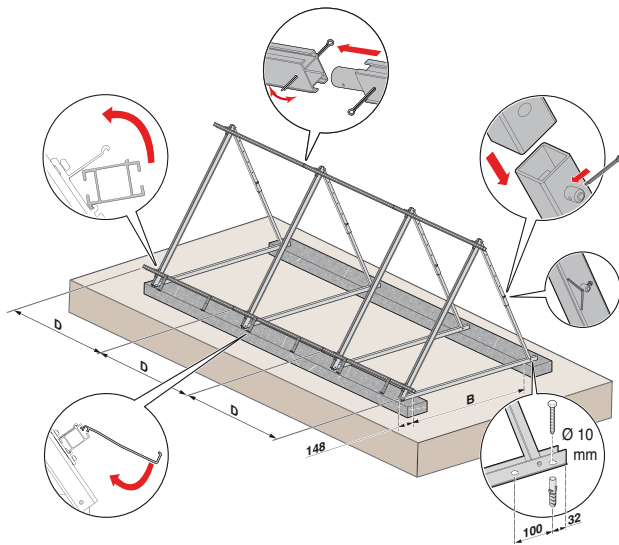

#### Mounting the collectors

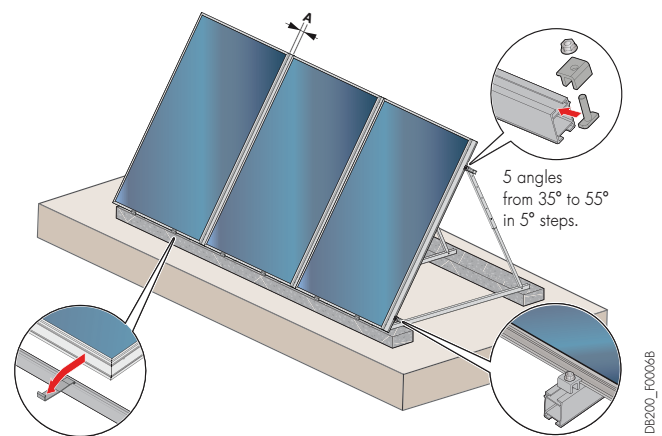

	A (mm)	B (mm)	D (mm)
DH 200 (SL)	87	1 245	1 254
CH 250 (SL)			

### ⇨ POWER 15

#### Mounting the supports and profiles

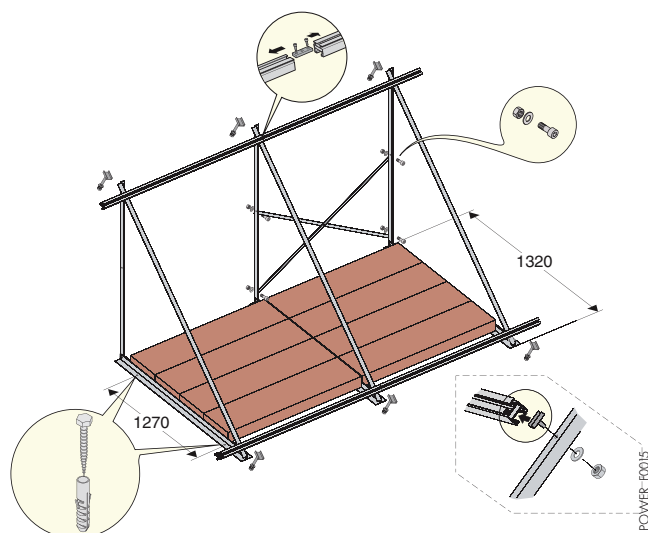

#### Position of profiles for each angle

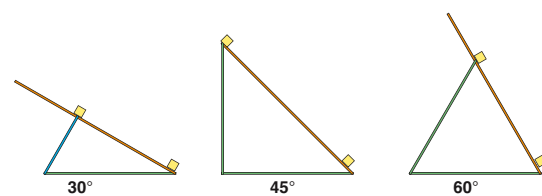

#### Mounting the collectors on the profiles

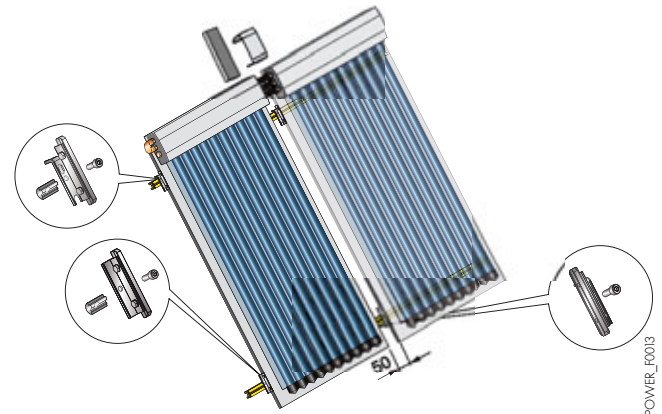

Tubular collectors are mounted on supports tilting to 30, 45 or 60° with cross members. You need 1 package of "3 supports with stabilising cross-pieces" per row of collectors.

# INSTALLING SOLAR COLLECTORS ON THE GROUND OR A TERRACE

## BALLASTS AND HOLDING POWER OF TERRACE SUPPORT FASTENING SCREWS

To take the wind load into account, depending on the installation zone and terrain category (see below), the structure supporting solar collectors needs to be secured:

- either by mounting sufficient ballasts,
- or by securing the terrace supports via their base.

Normal wind speeds	Zone (altitude < 50 m)			
	1 and 2	3	4	5
- in m/s	<24	26	28	30
- in km/h	≈ 85	95	100	110

Guadeloupe: 34 m/s (125 km/h)  
Reunion: 36 m/s (130 km/h)

**Note:** If using ballasts, you need to check the roof's capacity to withstand this additional load (including collectors). These ballasts must be mounted so that it cannot detach from the supports, and that all of the ballasts are resting on the supports.

### ⇒ Determining the ballasts

- **Urban zones:** refer to the table opposite, giving the weight of the ballasts to rest on the supports.
- **For non-urban zones, on an exposed site** such as an island, on the shore, or at altitude (mountain plateau), the multiplier shown opposite must be applied.
- The ballasts are given as per NV65 rules for a collector angle of **65°** (French rule).

### ⇒ Sizing the fastening screws

- **Urban areas:** to calculate the holding power of the support fastening screws, you need to refer to the holding power required for each collector (equivalent to the ballast weight defined above), divide it by 2 (2 fastening screws), and apply it to a screw/bolt Ø of 8 mm (fastening holes in supports: Ø 10 mm) - see table opposite.
- In the same way as for determining the ballasts, in exposed areas, these values should be adjusted by the multiplier shown.
- A fastening point may be one bolt or one screw in a dowel or any other retainer provided by means **of the two fastening holes for the collector supports.**
- The holding power of the support mounting points is determined as per standard EN 1991 for a collector angle of 65°.

European wind map

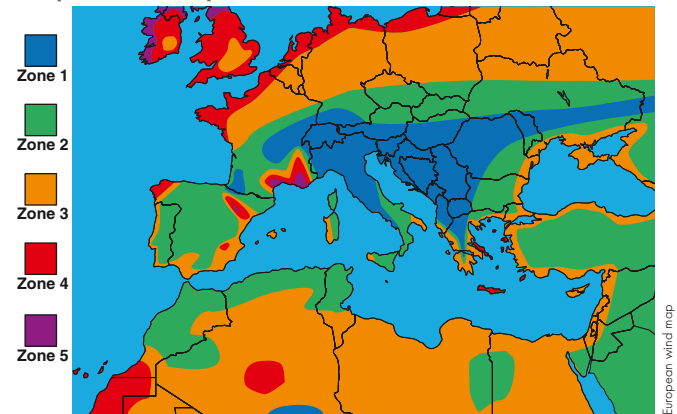

⚠ Map provided for information only.  
Make sure to check the wind speeds for the relevant country.

	Building height (m)	Ballast per collector (kg)				
		1 and 2	3	4	5	
DH 200 (SL) / POWER 15	≦ 10	- city	145	180	210	250
		- countryside	325	390	460	530
		- seaside	425	505	590	680
	10 to 20	- city	220	260	310	360
		- countryside	397	472	555	640
		- seaside	486	576	675	780
	20 to 30	- city	265	315	370	430
		- countryside	440	615	610	710
		- seaside	525	620	725	840
	30 to 40	- city	300	355	420	485
		- countryside	470	560	655	760
		- seaside	550	655	765	880
CH 250 (SL)	≦ 10	- city	180	220	260	305
		- countryside	405	485	570	660
		- seaside	525	625	735	850
	10 to 20	- city	270	325	385	445
		- countryside	495	585	685	795
		- seaside	605	715	840	970
	20 to 30	- city	335	390	450	535
		- countryside	545	650	760	880
		- seaside	650	770	905	1045
	30 to 40	- city	370	440	520	605
		- countryside	585	700	815	945
		- seaside	685	815	950	1095

	Building height (m)	Holding power of a fastening point (N)				
		1 and 2	3	4	5	
DH 200 (SL) / POWER 15	≦ 10	- city	360	440	530	620
		- countryside	820	980	1115	1330
		- seaside	1060	1260	1480	1710
	10 to 20	- city	550	660	770	900
		- countryside	990	1180	1390	1600
		- seaside	1220	1440	1690	1950
	20 to 30	- city	660	790	930	1080
		- countryside	1110	1310	1530	1770
		- seaside	1310	1560	1820	2100
	30 to 40	- city	750	890	1050	1220
		- countryside	1180	1410	1640	1900
		- seaside	1380	1640	1910	2210
CH 250 (SL)	≦ 10	- city	450	540	650	760
		- countryside	1010	1210	1420	1650
		- seaside	1320	1560	1830	2120
	10 to 20	- city	670	810	960	1120
		- countryside	1230	1470	1720	1990
		- seaside	1510	1790	2100	2430
	20 to 30	- city	810	980	1115	1340
		- countryside	1370	1630	1900	2200
		- seaside	1630	1930	2260	2610
	30 to 40	- city	920	1100	1300	1510
		- countryside	1470	1740	2040	2360
		- seaside	1710	2030	2380	2750

## SETTING UP THE SUPPORTS ON A TERRACE ROOF

The collectors must be set up on the roof as per DTU 65.12  
The collector fastenings must enable it to withstand the effects of normal load, wind and snow. Two possible

connection techniques between the collector supports and the roof are set out below.

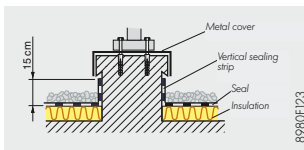

### Solution 1

The collectors support is fastened to a concrete block covered with a metal cover fitted to provide a leak-tight seal. The concrete block is made in accordance with standard NF P 10-203, DTU reference no. 2012.

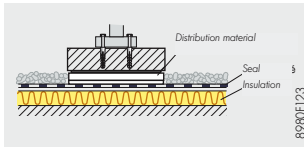

### Solution 2

The support can be held in place by anchoring the support foot in a solid concrete block, also providing ballast, mounted on the seal via a distribution material (expanded polystyrene

A 15 cm sealing strip is positioned vertically on the concrete block in accordance with standard NF P 84-204 to 208, DTU reference no. 43

for example). The solid concrete block must be removable, without using lifting machinery, to allow for the sealing coating to be redone if necessary.

## PIPE PENETRATIONS ON THE ROOF

Pipes must be routed so as to prevent any run-off water from entering the building.

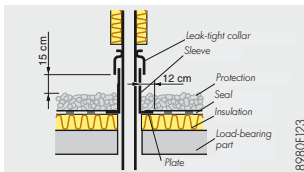

### Vertical penetration

In this case, the pipes are routed by means of a sleeve and plate in accordance with DTU no. 43 (leak-tight ventilation pipe connectors). The upper part of the sleeve is at least 15 cm above the coating protector. A collar is fitted to provide

a leak-tight seal on the tube carrying the heat-transporting fluid. It covers the sleeve over approximately 3 cm.

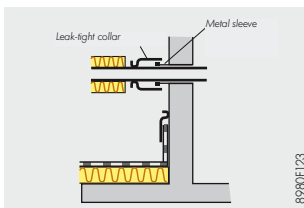

### Horizontal penetration

The pipes carrying the heat-transporting fluid are routed horizontally through a vertical wall leading to the building interior. The pipes are routed via a metal sleeve embedded in the vertical wall, and situated above the sealing band. The sleeve is finished with a rim forming

a drip groove all the way around its perimeter. A collar is fitted to provide a leak-tight seal on the tube carrying the heat-transporting fluid. It covers the sleeve over approximately 3 cm.

## PACKAGE LIST

	System for <b>ground or terrace installation</b>	Package no.	Number of collectors installed vertical in 1 row									
			1	2	3	4	5	6	7	8	9	10
DH 200 (SL) CH 250 (SL)	Profiles kit for 1 collector	ER732	1	2	3	4	5	6	7	8	9	10
	Basic terrace support for installing 1 collector	ER658	1	1	1	1	1	1	1	1	1	1
	Extension terrace support for installing 1 additional collector	ER659	-	1	2	3	4	5	6	7	8	9
	or											
	Profiles kit for 1 collector	ER732	1	2	3	4	5	6	7	8	9	10
	3 supports with stabilising cross-piece	EG358	1	1	1	1	1	1	1	1	1	1
3 supports without stabilising cross-piece	EG359	-	-	1	1	1	2	2	2	3	3	
POWER 15	Profiles kit for 1 collector	ER32	1	2	3	4	5	6	7	8	9	10
	Collectors-profiles fastening kit	ER392	1	2	3	4	5	6	7	8	9	10
	Tilting supports with stabilising cross-piece (for terrace installation):											
	- 3 supports with stabilising cross-piece	EG358	1	1	1	1	1	1	1	1	1	1
- 3 supports without stabilising cross-piece	EG359	-	-	1	1	1	2	2	2	3	3	

# INSTALLING SOLAR COLLECTORS ON A ROOF

## SIZING THE COLLECTOR FIELD

Roof installation of collectors such as we provide, in view of the thicknesses and set-up options, as well as the frame colours, is in every respect designed for optimal integration, while maintaining the advantages of roof installation, namely:

- the collectors are always accessible: the hydraulic parts and sensors can be checked and/or replaced if applicable, easily and at any time,

- the installation is not dependent on the roof angle, and set-up remains relatively simple, since it requires no knowledge of roofing,
- the stresses due to material expansion have no effect on the building's sealing over time, unlike roof installations with large collector fields, numerous superimposed sheets, repeated jointing subject to very low temperatures in winter and very high temperatures in summer.

### Collector field width

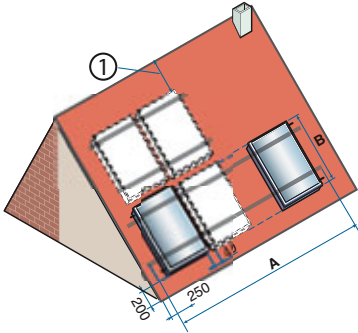

① Min. of 3 rows of tiles

		Number of collectors on 1 vertically installed row									
		1	2	3	4	5	6	7	8	9	10
A (m)	DH 200 (SL)	1.3	2.5	3.7	5.0	6.2	7.4	8.7	9.9	11.1	12.4
	CH 250 (SL)	1.3	2.6	3.9	5.2	6.5	7.8	9.1	10.4	11.7	13.0
	POWER 15	1.3	2.6	3.9	5.2	6.5	7.8	9.1	10.4	11.7	13.0

PROD\_F0051

		DH 200 (SL)	CH 250 (SL)	POWER 15
B (m)		1.8	2.2	1.7

## TERRACE INSTALLATION WITH SUPPORTS (MOUNTED VIA PROFILES ON SUPPORT FEET)

### Installation principle

The collectors are mounted on the roof via profiles combined with anchor fittings (to be chosen according to the roofing type).

Each "Profiles" kit comes with the coupling parts to the profiles of the following collector.

### DH 200 (SL) and CH 250 (SL)

#### Mounting the profiles

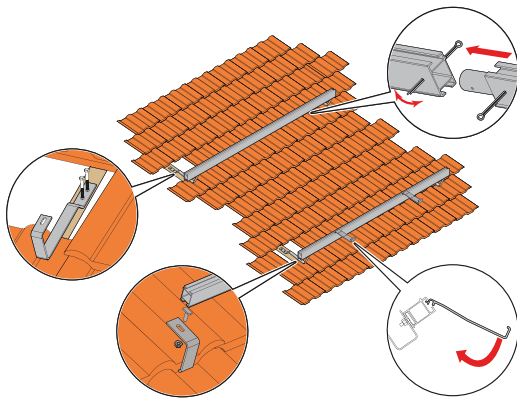

PROD\_F0026

#### Mounting the collectors

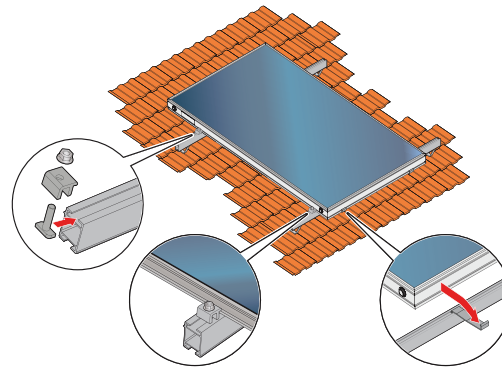

PROD\_F0027

### POWER 15

#### Mounting the profiles and collectors

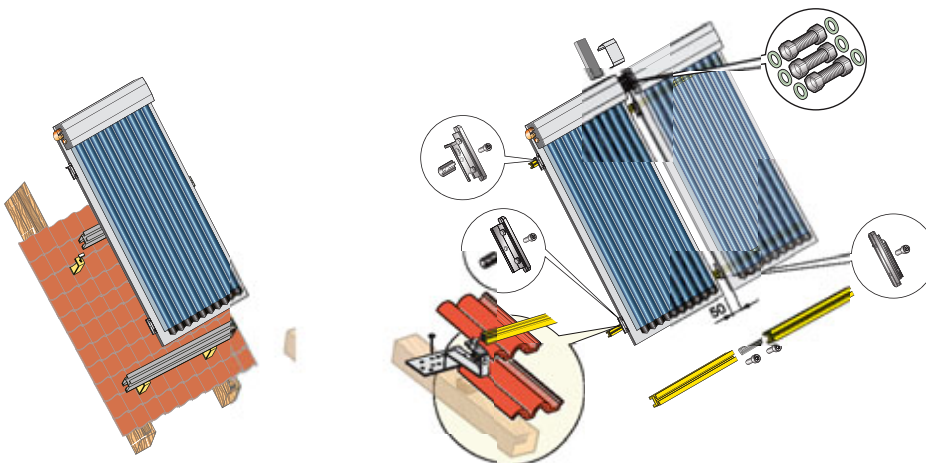

POWER\_F0006A

⇒ Anchor fitting to be chosen according to the roofing type

- for independent installation of the rafters on 2 wooden battens, 30 x 90 mm (to be provided by the installer): universal aluminium hooks

For mechanical or Roman tiles

EG311: 4 pieces  
EG312: 6 pieces

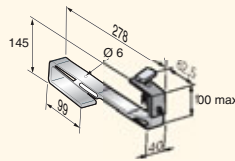

- for installation on rafters via stainless steel wood screws: stainless steel anchor fittings

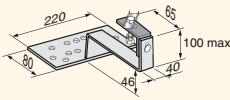
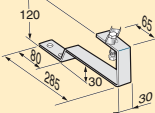
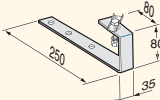
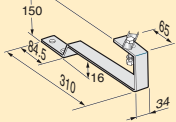
For mechanical tiles	For flat tiles	For slates/cladding	For Roman tiles
EG313: 4 pieces EG314: 6 pieces 	EG315: 4 pieces EG316: 6 pieces 	EG319: 4 pieces EG320: 6 pieces 	ER136: 4 pieces ER137: 6 pieces 

- lag screw for installation on rafters through the roofing

EG94: 6 pieces  
EG95: 8 pieces







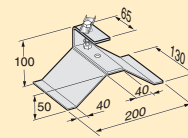



- stainless steel fittings for eternit roof or cladding through the roofing

EG317: 4 pieces  
EG318: 6 pieces



## PACKAGE LIST

System for roof installation		Pencil icon	Package no.	Number of collectors installed in 1 row										
				1	2	3	4	5	6	7	8	9	10	
DH 200 (SL) DH 200 (SL)	Kit of profiles for 1 DH 200 (SL) or CH 250 (SL) collector (to be combined with anchor fittings)		ER732	1	2	3	4	5	6	7	8	9	10	
	Kit of profiles for 1 POWER 15 collector (to be combined with anchor fittings)		ER32	1	2	3	4	5	6	7	8	9	10	
POWER 15	Kit for fastening POWER 15 collectors on profiles		ER392	1	2	3	4	5	6	7	8	9	10	
	Anchor fittings to be combined with profiles (1)													
⇒ mechanical tiles:														
- Universal aluminium hooks for independent installation of rafters on 2 wooden battens, cross-section 30x90 mm, supplied		4 pieces	EG311	1	-	2	1	-	2	1	-	2	1	
		6 pieces	EG312	-	1	-	1	2	1	2	3	2	3	
or														
- Stainless steel anchor fittings for installation on rafters via stainless steel wood screws		4 pieces	EG313	1	-	2	1	-	2	1	-	2	1	
		6 pieces	EG314	-	1	-	1	2	1	2	3	2	3	
⇒ tiles:														
- Stainless steel anchor fittings for installation on rafters via stainless steel wood screws	Flat EG315 	Roman EG136 	4 pieces	(2)	1	-	2	1	-	2	1	-	2	1
	EG316 	EG137 	6 pieces	(2)	-	1	-	1	2	1	2	3	2	3
⇒ slates, cladding:														
- Stainless steel anchor fittings for installation on rafters via stainless steel wood screws		4 pieces	EG319	1	2	-	1	1	2	1	-	2	1	
		6 pieces	EG320	-	-	2	1	2	1	2	3	2	3	
⇒ eternit or cladding:														
- Through the roofing, stainless steel anchor fittings		4 pieces	EG317	1	-	2	1	-	2	1	-	2	1	
		6 pieces	EG318	-	1	-	1	2	1	2	3	2	3	
⇒ Lag screws kit:														
- For installation on rafters through the roofing		6 pieces	EG94	1	-	2	-	1	2	1	-	2	1	
		8 pieces	EG95	-	1	-	2	2	1	2	3	2	3	

(1) ⚠ In regions of heavy snowfall and with roof slopes ≤ 35°, the number of hooks must be doubled.

(2) To be chosen depending on the type of roofing in addition to the profiles.

8980C077F

8980C077F

8980C018 + 8980C077F

# DOMESTIC SOLAR INSTALLATIONS FOR DHW PRODUCTION

We offer the following 5 systems for domestic hot water production.

## DHW PRODUCTION SYSTEM WITH BUILT-IN HYDRAULIC BACK-UP

This system will be installed with BSL.. N solar tanks with heat exchanger for built-in hydraulic back-up.

### Technical specifications of BSL.. N solar tanks

#### Description

Glass-lined steel tank with CFC-free injected polyurethane foam insulation, thickness 50 mm.  
Lower and upper solar exchangers for the boiler comprising smooth tubes with external glass lining.

Rear connections except for solar heat exchanger connection on the front.  
Magnesium anode protection.  
ABS casing and covers.



#### Main dimensions

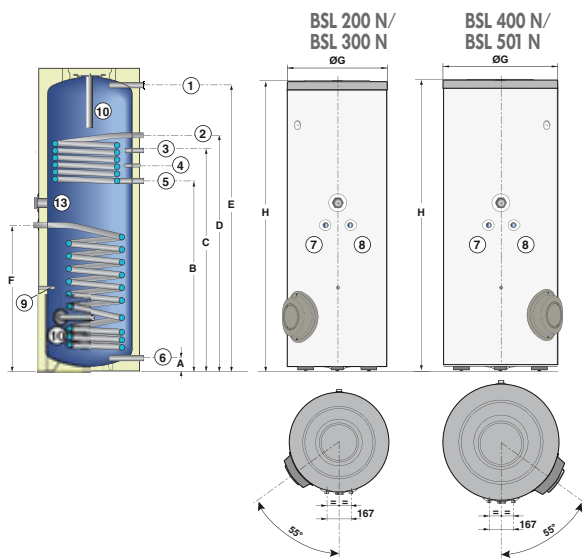

Type	BSL 200 N	BSL 300 N	BSL 400 N	BSL 501 N
A	71	71	66	71
B	912	1127	992	1133
C	1092	1397	1217	1313
D	1182	1397	1262	1403
E	1324	1694	1558	1666
F	682	862	812	948
G Ø	604	604	704	811
H	1423	1796	1672	1812

- ① Domestic hot water outlet G 1
- ② Heat exchanger inlet G 1
- ③ Circulation G 3/4
- ④ Domestic hot water sensor position
- ⑤ Heat exchanger outlet G 1
- ⑥ Domestic cold water inlet + Drain G 1
- ⑦ Solar exchanger inlet G 3/4
- ⑧ Solar exchanger outlet G 3/4
- ⑨ Solar sensor position
- ⑩ Anode
- ⑬ Position for optional immersion heater

### Table of specifications

#### Conditions of use:

Maximum operating temperature: - primary (exchangers): 110 °C  
- secondary (tank): 95 °C

Maximum operating pressure: - primary (exchangers): 10 bar  
- secondary (tank): 10 bar

		BSL 200 N		BSL 300 N		BSL 400 N		BSL 501 N	
		C		C		C		C	
Useful tank capacity	L	225		300		400		500	
Hydraulic back-up volume	L	75		105		150		160	
Solar volume	L	150		195		250		340	
Heat exchanger		lwr (sol.)	upp. (boil.)	lwr (sol.)	upp. (boil.)	lwr (sol.)	upp. (boil.)	lwr (sol.)	upp. (boil.)
Exchanger capacity	L	5.6	5.1	8.1	5.1	10.1	5.1	12.8	5.1
Exchange surface area	m <sup>2</sup>	0.84	0.76	1.2	0.76	1.5	0.76	1.9	0.76
Primary flow rate	m <sup>3</sup> /h	2		2		2		2	
Primary temperature	°C	-	70 80	-	70 80	-	70 80	-	70 80
Exchanged power (I) (2)	kW	-	15 24	-	15 24	-	15 24	-	15 24
Hourly flow rate at ΔT 35 K (I)(2)	L/h	-	380 590	-	380 590	-	380 590	-	380 590
Flow rate in 10 mins at ΔT 30 K (I)(3)	L/10 mins	-	150 150	-	200 200	-	270 270	-	305 305
Tank heat loss coefficient (UA S)	W/K	1.67		2.04		2.41		2.56	
Shipping weight	kg	99		122		149		180	

(I) Cold water temp.: 10 °C (2), DHW temp. 45 °C, primary temp. at 80 °C, primary flow rate 2 m<sup>3</sup>/h. (3) DHW temp. 40 °C, DHW storage temp. 65 °C, values measured using the back-up volume only

#### Options



**Thermostatic mixing valve - Package EC60**



**Cold water connection kit - Package ER404**



#### Shielded immersion heater:

- 1.5 kW with thermostat - Package ER395
- 2.3 kW with thermostat - Package ER396
- 3 kW with thermostat - Package ER397
- 1.5 kW with sensor - Package ER392 (for SOL AEL solar regulator only)
- 3 kW with sensor - Package ER394 (for SOL AEL solar regulator only)

⇒ Example of installation

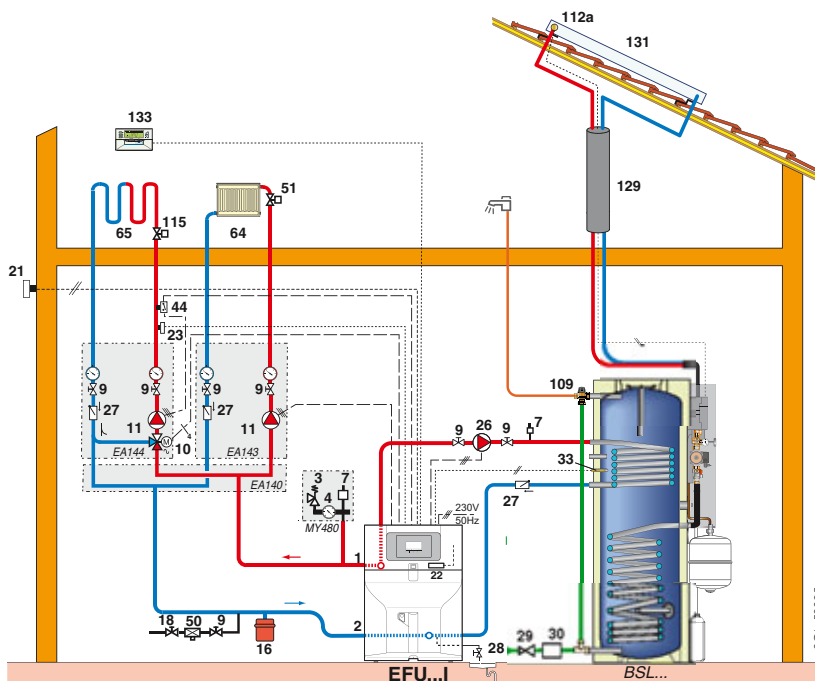

BSL.. N tank with DKSL 6-8 MSB solar station (ER710) mounted on the tank via connection tubes (ER414), SOL AEL regulator (ER708), immersion heater (ER392 or ER394, optional) and expansion vessel.

The BSL.. N solar tank is connected to the collector field in a pressurised solar system (or self-draining system, depending on the solar station used) via the solar exchanger situated at the bottom of the tank. This circuit will heat the DHW according to the available solar energy.

In the upper part of the tank, a second heat exchanger connected to a boiler (possibly supplemented by an immersion heater) enables the desired DHW temperature to be obtained should the solar circuit be insufficient. This solution is more compact and efficient than a system with 2 tanks, but is limited in DHW flow; this system is not recommended with very high DHW requirements.

The electrical back-up (optional) may enable the boiler to be shut down in the summer.

⇒ Recommended solar collector/tank pairings

		Package No.	Number of people			
			3 to 4 	4 to 5 	5 to 6 	7 to 8 
Solar collector	DH 200 (SL)	See pages 4 and 6				
Solar tank	BSL 200 N	ER418	x			
	BSL 300 N	ER419		x		
	BSL 400 N	ER420			x	x
	BSL 501 N	ER883			x	x

⇒ Accessories for solar circuit

- DKSL 6-8 MSB solar station - Package ER710
- Tubing kit for installing the DKSL 6-8 MSB station on the BSL 200 to 501 N tank - Package ER414
- SKP 7-8 solar station - Package ER655
- SOL PLUS regulator - Package ER709
- SOL AEL regulator - Package ER708
- Solar circuit expansion vessel (6 bar - 120 °C):
  - 18 litres - Package EG117
  - 24 litres - Package EG118
- Wall attachment kit for expansion vessel up to 25 litres - Package EC118
- Heat-transporting fluid:
  - BIO premix (20 l) down to - 30 °C - Package ER316
  - high-performance premix (20 l) down to - 26 °C - Package EG100
  - standard premix (20 l) down to - 21 °C - Package EG101

**NB :** for a complete description of these accessories, please refer to pages 26 to 29.

# DOMESTIC SOLAR INSTALLATIONS FOR DHW PRODUCTION

## DHW PRODUCTION SYSTEM WITH BUILT-IN ELECTRICAL BACK-UP

This system will be installed with BESL.. N tanks (possibly BSL 501 N) to be equipped with an immersion heater.

↳ **Technical specifications of BESL.. N solar tanks (BSL 501 N tank, see page 16)**

### Description

Glass-lined steel tank with CFC-free injected polyurethane foam insulation, thickness 50 mm.  
Lower solar exchanger comprising smooth tubes with external glass lining.

Rear connections except for solar heat exchanger connection on the front.  
Magnesium anode protection.  
ABS casing and covers.



### Main dimensions

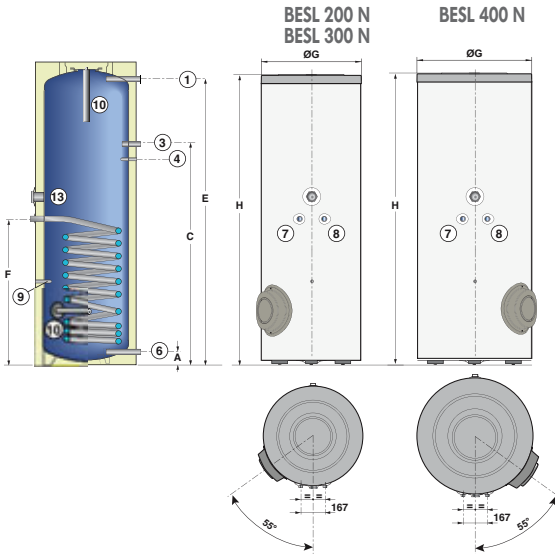

Type	BESL 200 N	BESL 300 N	BESL 400 N
A	71	71	66
C	1092	1397	1217
E	1324	1694	1558
F	682	862	812
G Ø	604	604	704
H	1423	1796	1672

- ① Domestic hot water outlet G1
- ③ Circulation G 3/4
- ④ Domestic hot water sensor position
- ⑥ Domestic cold water inlet + drain G1
- ⑦ Solar exchanger inlet: G 3/4
- ⑧ Solar exchanger outlet: G 3/4
- ⑨ Solar sensor position
- ⑩ Anode
- ⑬ Position for optional immersion heater

### Table of specifications

#### Conditions of use:

Maximum operating temperature: - primary (exchanger): 110 °C  
- secondary (tank): 95 °C

Maximum operating pressure: - primary (exchanger): 10 bar  
- secondary (tank): 10 bar

		BESL 200 N	BESL 300 N	BESL 400 N	BSL 501 N
Energy efficiency class		C	C	C	C
Useful tank capacity	L	225	300	400	500
Electrical back-up volume	L	95	135	170	190
Solar volume	L	130	165	230	310
Solar exchanger capacity	L	5.6	8.1	10.1	12.8
Solar exchange surface area	m <sup>2</sup>	0.84	1.20	1.50	1.90
Heat loss coefficient (UA <sub>S</sub> )	W/K	1.67	2.04	2.41	2.56
Available water volume at 40 °C (Ves 40) in continuous heating with immersion heater:	- 1.5 kW	L	250	-	-
	- 2.3 kW	L	305	360	-
	- 3 kW	L	-	415	510
Back-up volume heating time	h	3 hrs 20	3 hrs 10	3 hrs	3 hrs 25
Weight empty	kg	86	97	126	180

### Options

#### ER397



BSL\_Q0009

#### Shielded immersion heater:

- 1.5 kW with thermostat - Package ER395
- 2.3 kW with thermostat - Package ER396
- 3 kW with thermostat - Package ER397



8990Q302

#### Thermostatic mixing valve - Package EC60



BSL\_Q0008

#### Cold water connection kit - Package ER404

### ⇒ Example of installation

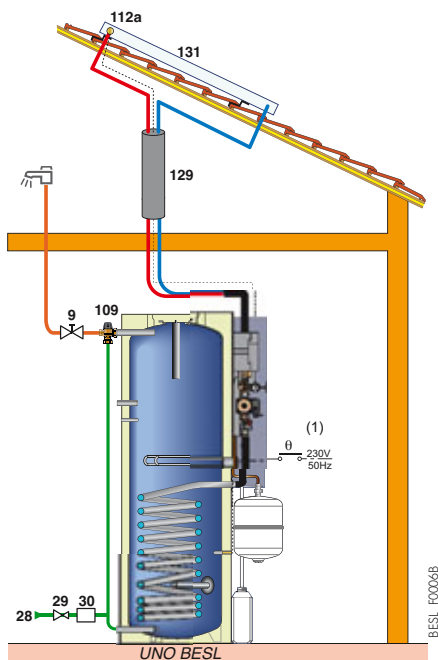

(1) Summer

BESL.. N tank with DKSL 6-8 MSB solar station (ER710) mounted on the tank via connection tubes (ER414), SOL AEL regulator (ER708), immersion heater (ER392 or ER394) and expansion vessel.

The BESL.. N solar tank is connected to the collector field in a pressurised solar system (or self-draining system, depending on the solar station used) via the solar exchanger situated at the bottom of the tank. This circuit will heat the DHW according to the available solar energy.

An immersion heater inside the tank enables the desired DHW temperature to be obtained should the solar circuit be insufficient. This system can be installed in place of a conventional electric water heater for example, or upstream of DHW production with a boiler if the latter needs to be shut down for the summer.

In low-sunlight regions, you must take care that the DHW requirements correspond to the volume which can be heated by the back-up.

### ⇒ Recommended solar collector/tank pairings

		Package No.	Number of people			
			2 to 3 	3 to 4 	4 to 5 	5 to 6 
Solar collector	DH 200 (SL)	See pages 4 and 6				
Solar tank	BESL 200 N	ER421	x			
	BESL 300 N	ER422		x		
	BESL 400 N	ER423			x	
	BSL 501 N	ER883			x	x

### ⇒ Accessories for solar circuit

- DKSL 6-8 MSB solar station - Package ER710
- Tubing kit for installing the DKSL 6-8 MSB station on the BESL 200 to 400 N tank - Package ER414
- SKP 7-8 solar station - Package ER655
- SOL PLUS regulator - Package ER709
- SOL AEL regulator - Package ER708
- Solar circuit expansion vessel (6 bar - 120 °C): - 18 litres - Package EG117  
- 24 litres - Package EG118
- Wall attachment kit for expansion vessel up to 25 litres - Package EC118
- Heat-transporing fluid: - BIO premix (20 l) down to - 30 °C - Package ER316  
- high-performance premix (20 l) down to - 26 °C - Package EG100  
- standard premix (20 l) down to - 21 °C - Package EG101

**NB :** for a complete description of these accessories, please refer to pages 26 to 29.

# DOMESTIC SOLAR INSTALLATIONS FOR DHW PRODUCTION

## DHW PRODUCTION AND POOL BACK-UP SYSTEM

This system will be installed with double-coil tanks with a capacity of 400 to 1000 litres.

⇒ Technical specifications of B 802 and 1002 HR tanks (BSL.. N, see page 16)

Description (see page 30)

Main dimensions

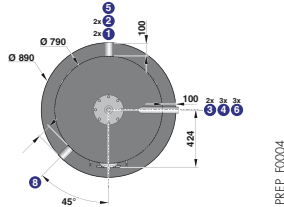
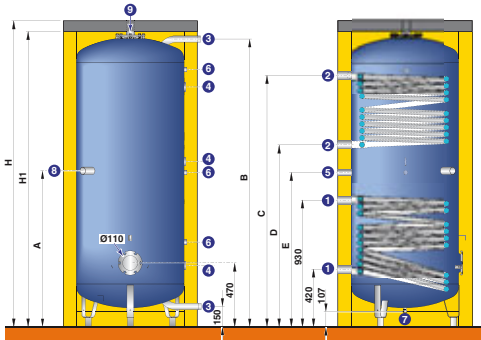

- ① Solar exchanger inlet/outlet Rp 1" 1/2
- ② Boiler heat exchanger inlet/outlet Rp 1" 1/2
- ③ Storage water inlet/outlet Rp 1" 1/2
- ④ Sensor tube, Ø 6 mm
- ⑤ Recirculation Rp 1"
- ⑥ Sleeve for sensor tube/anodes 3/4"

Type	B 802 HR	B 1002 HR
H	2 055	2 271
H1	1 955	2 171
A	976	1 147
B	1 889	2 115
C	1 542	1 847
D	1 134	1 337
E	1 024	1 133

- ⑦ Drain with plug R 3/4"
- ⑧ Immersion heater end-fitting Rp 1" 1/2
- ⑨ Domestic hot water outlet/vent Rp 2"

Switch dimension: 2010 mm

⇒ Table of specifications

Conditions of use:

Maximum operating temperature: - primary (exchanger): 95 °C  
- secondary (tank): 95 °C

Maximum operating pressure: - primary (exchanger): 12 bar  
- secondary (tank): 7 bar

Model		B 802				B 1002			
		bottom (solar)		top (boiler)		bottom (solar)		top (boiler)	
Tank capacity	L	800				1000			
Back-up volume/Solar volume	L	310/490				350/650			
Heat exchanger		bottom (solar)		top (boiler)		bottom (solar)		top (boiler)	
Exchanger capacity	L	15.2		14.4		16.1		16.0	
Exchange surface area	m <sup>2</sup>	2		1.9		2.1		2.1	
Primary flow rate	m <sup>3</sup> /h	0.5		3		0.5		3	
Water pressure drop	mbar	-		150		-		135	
Primary inlet temperature	°C	50	70	70	80	50	70	70	80
Exchanged power (I) (2)	kW	4.5	12.5	29	39	4.8	13.2	32	43
Hourly flow rate (I) (2)	l/h	-	-	370	960	-	-	410	1050
Max. flow rate in 10 mins at ΔT 30 K (I)(3)	l/10 mins	-		420		-		465	
Heat loss coefficient UA (with HR casing)	W/K	2.12				2.43			
Shipping weight	kg	270				335			

(I) Cold water temp. 10°C (2) DHW temp. 45°C (3) DHW temp. 40°C, DHW storage temp. 65°C, values measured using the back-up volume only

Option



6 kW/400 V shielded immersion heater, 1" 1/2 - Package AJ36

⇒ Example of installation

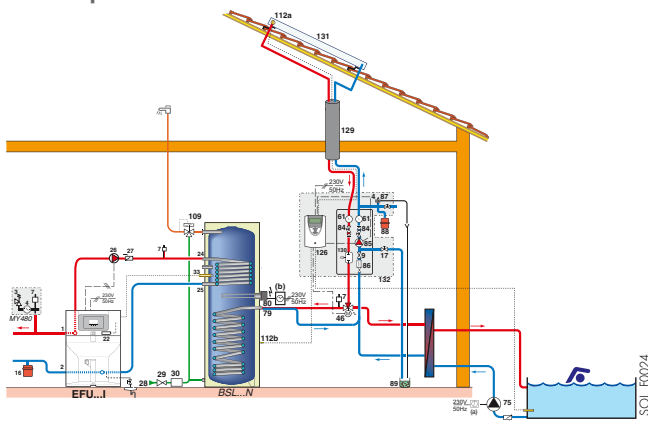

BSL..N or B.. tank with wall-mounted DKSL 6-8 MSB solar station (ER710), SOL PLUS regulator (ER709), immersion heater (ER395, ER396 or ER 397 - optional) and expansion vessel.

BSL.. N or B 802 HR solar tanks are connected to the collector field in a pressurised solar system (or self-draining system, depending on the solar station used) via the solar exchanger situated at the bottom of the tank. This circuit will heat the DHW according to the available solar energy.

An immersion heater (optional) inside the tank enables the desired DHW temperature to be obtained should the solar circuit be insufficient and the boiler be shut down. When this solution is operating with a larger solar surface area (limited by the surface area of the tank solar exchanger), it can heat the pool if DHW demand is satisfied by the solar circuit, via a plate heat exchanger connected in parallel to the solar circuit and in series to the pool filtering circuit.

⇒ Recommended solar collector/tank pairings

		Package no.	Number of people	
			7 to 8	≥ 9
Solar collector	DH 200 (SL)	See pages 4 and 6		
Solar tank	BSL 400 N	ER420	x	
	BSL 501 N	ER883	x	
	B 802 HR	AJ85 + AJ95		x
	B 1002 HR	AJ86 + AJ97		x

⇒ Accessories for solar circuit: all options on page 17.

## SYSTEM WITH DHW PREHEATING

This solar system uses single-coil BESL.. N (or BSL 150 N) solar tanks.

DHW preheating is provided by an instant DHW production gas boiler

### Technical specifications of BSL 150 N tank (BESL.. N, see page 18)

#### Description

Glass-lined steel tank with CFC-free injected polyurethane foam insulation, thickness 50 mm.

Lower solar exchanger comprising smooth tubes with external glass lining.

Rear connections except for solar heat exchanger connection on the front.

Magnesium anode protection.

ABS casing and covers.



#### Main dimensions

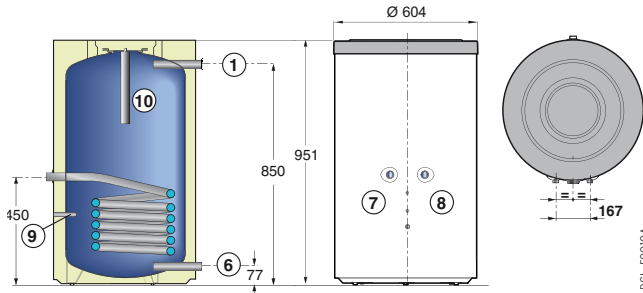

- ① Domestic hot water outlet
- ② Domestic cold water inlet + Drain G 1
- ③ Solar exchanger inlet G 3/4
- ④ Solar exchanger outlet G 3/4

- ⑨ Solar sensor position
- ⑩ Anode

G: cylindrical external threading (sealed by flat gasket)

#### Table of specifications

##### Conditions of use:

Maximum operating temperature: - primary (exchanger): 110 °C  
- secondary (tank): 95 °C

Maximum operating pressure: - primary (exchanger): 10 bar  
- secondary (tank): 10 bar

		<b>BSL 150 N</b>	
Tank capacity	L	147/141	
Exchanger capacity	L	5	
Exchange surface area	m <sup>2</sup>	0.75	
Heat loss coefficient UA	W/K	1.3	
Net weight	kg	55	

### Example of installation

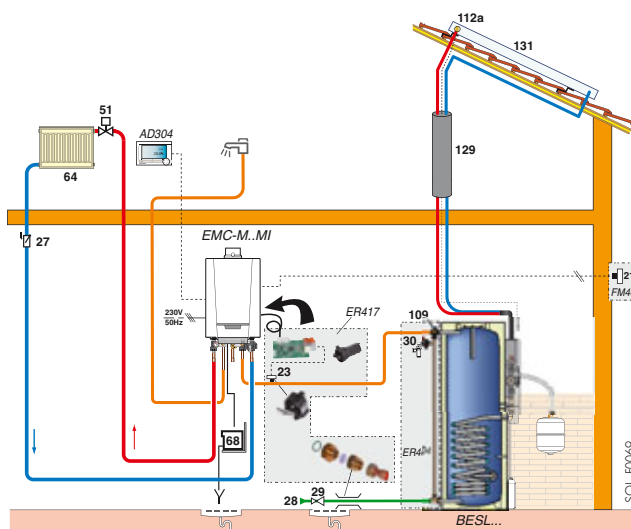

BESL..N tank with solar station SKP 7-8 (ER655) mounted directly on the tank, SOL PLUS regulator (ER709) and expansion vessel with support..

The BESL..N solar tank is connected to the collector field in a pressurised solar system (or self-draining system, depending on the solar station used) via the solar exchanger situated at the bottom of the tank. This circuit will heat the DHW according to the available solar energy.

The solar tank DHW outlet is connected to the cold water inlet of the back-up generator, which may be: either an instant DHW production combi boiler, or a boiler with a DHW tank, or also a gas or electric water heater. This back-up generator will ensure the desired DHW temperature should the solar circuit not be sufficient.

This solution may be set up on any existing installation (non-solar), even with high DHW requirements, with all BSL.. N tanks from 150 to 500 litres.

### Recommended solar collector/tank pairings

		Package no.	Number of people		
			3 to 4	4 to 5	5 to 6
Solar collector	DH 200 (SI)	See pages 4 and 6			
	BSL 150 N	ER284	x		
Solar tank	BESL 200 N	ER421	x		
	BESL 300 N	ER422		x	
	BESL 400 N	ER423		x	x

### Accessories for solar circuit: all options on page 17 and the following 2 options.

- DKSC 6 MSB solar station for BSL 150 N tank - Package ER711
- Tubing kit for installing the DKSC 6 MSB station on the BSL 150 N tank - Package ER286

# DOMESTIC SOLAR INSTALLATIONS FOR DHW PRODUCTION

## DHW PRODUCTION BY THERMOSIPHON SYSTEM

### Technical specifications of STMO solar systems

#### Description

Complete solar systems for DHW production. Fully autonomous operation based on the principle of natural water circulation (thermosiphon), installed directly on a roof or terrace.

They comprise:

- a double-shell glass-lined steel tank with magnesium anode protection, injected polyurethane foam insulation, thickness 35 mm for 150 L and 50 mm for 200 L and 300 L, and painted steel casing, factory-equipped with a 2 kW immersion heater,

- 1 or 2 flat solar collectors, standard version or "Slim Line" version,
- a terrace installation support,
- the hydraulic connection kit between collectors and tank, including the 7-bar DHW safety valve.



STMO\_G0002

#### STMO... (TER) main dimensions

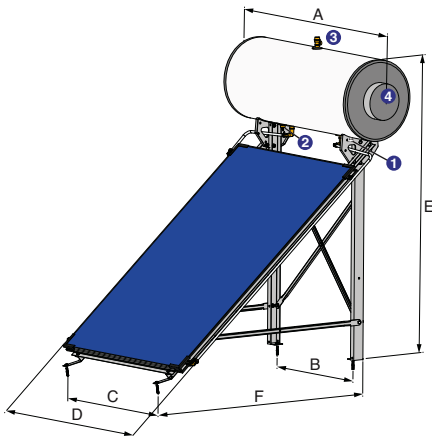

- ① Cold water inlet with 7-bar DHW safety valve, G 1/2 M
- ② DHW outlet G 1/2 M
- ③ 3-bar solar safety valve
- ④ 2 kW/230V immersion heater position

STMO (SE) type	150-2	200-2	200-3	300-4 TER
A (mm)	1 279	1 305	1 305	1 820
B (mm)	750	750	750	1 295
C (mm)	895	895	895	1 436
D (mm)	1 265	1 265	1 265	2 500
E (mm)	1 882	1 962	1 962	1 962
F (mm)	1 565	1 565	2 031	1 565

#### STMO... (S/TOIT) main dimensions

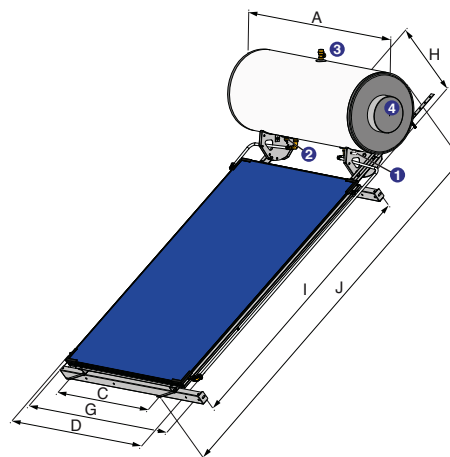

- ① Cold water inlet with 7-bar DHW safety valve, G 1/2 M
- ② DHW outlet G 1/2 M
- ③ 3-bar solar safety valve
- ④ 2 kW/230V immersion heater position

STMO (SE) type	150-2	200-2	200-3	300-4 S/TOIT	300-5 S/TOIT
A (mm)	1 279	1 305	1 305	1 820	1 820
C (mm)	895	895	895	1 436	1 436
D (mm)	1 265	1 265	1 265	2 500	2 500
G (mm)	1 362	1 362	1 362	1 540	1 540
H (mm)	678	755	755	755	755
I (mm)	1 790	1 790	1 790	1 790	2 223
J (mm)	2 326	2 397	2 831	2 397	2 831

#### Table of specifications

##### Remarks:

For the technical specifications of the solar collectors delivered in STMO systems, see pages 4 and 6.

Maximum operating pressure: 8 bar  
Maximum operating temperature: 102 °C

System	STMO	150-2	200-2	200-3	300-4	300-5	
Number and type of collectors		1 x DH 200 (SL)	1 x DH 200 (SL)	1 x CH 250 (SL)	2 x DH 200 (SL)	2 x CH 250 (SL)	
Collector inlet surface area A <sub>a</sub>	m <sup>2</sup>	1.92	1.92	2.40	3.84	4.80	
Tank capacity	L	150	200	200	300	300	
Primary circuit total capacity, standard collectors/SL	L	9.6/9.2	9.6/9.2	10.8/10.3	22.8/22.0	25.2/24.2	
DHW heating time* with sun only (1800 W/m <sup>2</sup> ) - from 20 to 40 °C	h	< 8 hrs	< 9 hrs	< 8 hrs	< 7 hrs	< 5 hrs	
Quantity of DHW heated by heating time with immersion heater only (2 kW)	- from 10 to 40 °C	L	80 L / 1 hr 30	100 L / 2 hrs	100 L / 2 hrs	150 L / 3 hrs	150 L / 3 hrs
	- from 10 to 60 °C	L	80 L / 2 hrs 30	100 L / 3 hrs 10	100 L / 3 hrs 10	150 L / 5 hrs	150 L / 5 hrs
Solar efficiency indicators for Athens (EN 12976)	- for an average annual demand of ... L DHW/day) at 45 °C	L/day	150	200	200	300	300
	- Q <sub>d</sub>	MJ	6 239	8 319	8 319	12 478	12 478
	- Q <sub>l</sub>	MJ	4 348	5 107	5 763	8 451	9 732
	- f <sub>sol</sub> (solar input)	%	69.7	61.4	69.3	67.7	78.0

\* In winter, you need to add 2 hrs, assuming cold water at 10 °C

## Installation principle

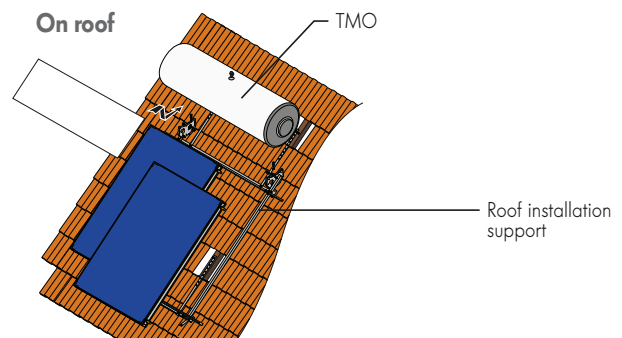
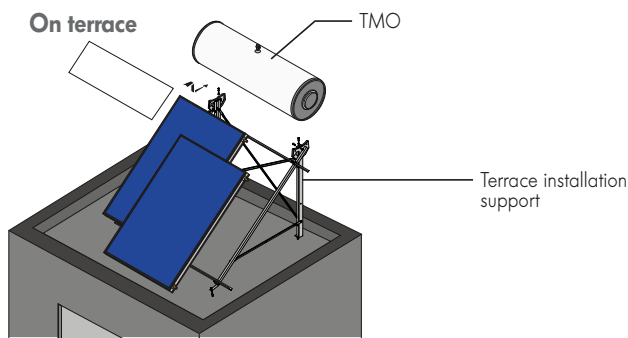

SOL\_F0041

SOL\_F0042

## ⇒ Example of STMO installation

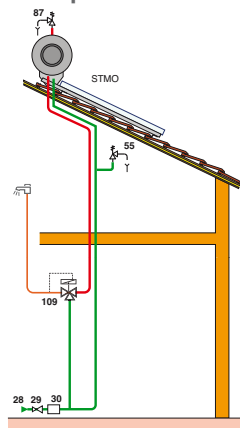

SOL\_F0040

The complete solar system (collectors plus DHW tank) is installed outside on a sloping roof or terrace. The collectors heat the tank via the solar circuit filled with glycol water (mix with 10 to 30 % glycol) by thermosiphon as soon as the sun shines. This system does not need any additional energy, and operates wherever there is no frost risk. An electrical back-up is built into the tank for sun-free periods. For tanks with DHW storage, the only periodic maintenance consists in checking the anode; for tanks with a domestic exchanger there is no maintenance. Thermosiphon systems are auto-protected against overheating, and can operate alone or preheating another DHW generator (see § "DHW preheating system" on the previous pages).

## ⇒ Recommendations and packing list

### • with SL collectors

Number of people ▶		2 to 3	3 to 4	4 to 5	> 5	
Collector type ▶		DH 200 SL	DH 200 SL	CH 250 SL	DH 200 SL	
<b>Complete kit</b>	Type/Reference for installation:					
	- on terrace	STMO SE 150-2	STMO SE 200-2	STMO SE 200-3	STMO SE 300-4 TER	STMO SE 300-5 TER
	- on roof	7220751	7220752	7656757	7220753	7656759
<b>In detail</b>	Tank type/reference	TMO 150 7217579	TMO 200 7217580	TMO 200 7217580	TMO 300 7217581	TMO 300 7217581
	STMO SE installation kits reference:					
	- on terrace	7220620	7220620	7220621	7220622	7220625
	- on roof				7220624	7220626
Collector type/reference	1 x DH 200 SL 1 x 7219377	1 x DH 200 SL 1 x 7219377	1 x CH 250 SL 1 x 7219376	2 x DH 200 SL 2 x 7219377	2 x CH 250 SL 2 x 7219376	
<b>Option:</b> trim	ER738: 7214201	ER738: 7214201	ER738: 7214201	ER739: 7214225	ER739: 7214225	

### • with standard collectors

Number of people ▶		2 to 3	3 to 4	4 to 5	> 5
Collector type ▶		DH 200	DH 200	DH 200	CH 250
<b>Complete kit</b>	Type/Reference for installation:				
	- on terrace	STMO 150-2	STMO 200-2	STMO 300-4 TER	-
	- on roof	7219371	7219372	7219373	STMO 300-5 S/TOIT
<b>In detail</b>	Tank type/reference	TMO 150 7217579	TMO 200 7217580	TMO 300 72175781	TMO 300 72175781
	STMO installation kits reference:				
	- on terrace	7214185	7214185	7214188	7214190
	- on roof			7214189	7214191
Collector type/reference	1 x DH 200 1 x 7203638	1 x DH 200 1 x 7203638	2 x DH 200 2 x 7203638	2 x CH 250 2 x 7219376	
<b>Option:</b> trim	ER738: 7214201	ER738: 7214201	ER739: 7214225	ER739: 7214225	

## ⇒ Accessories for solar circuit

- Heat-transporing fluid: - BIO premix (20 l) down to - 30 °C - Package ER316
  - high-performance premix (20 l) down to - 26 °C - Package EG100
  - standard premix (20 l) down to - 21 °C - Package EG101
- } See page 28

# DOMESTIC SOLAR INSTALLATIONS FOR COMBINED

These systems use QUADRO mixed solar tanks or BSL 501 N (or B 802) double-coil tanks, combined with a buffer tank.

## ⇒ Technical specifications of QUADRO SolarEasy tanks (B 802: see page 20; BSL 501 N: see page 16)

### Description

Solar tanks with optimised stratification to ensure solar input in all installation configurations.

Ribbed stainless steel high-efficiency DHW heat exchanger for instant DHW counter-current production in the back-up part, for high DHW flow rates.

Universal use, thanks to their connectability at various levels, providing modularity of DHW/heating back-up and solar areas depending on the generators used.

Modular installation, with minimum floor space requirement for guaranteed accessibility in all configurations, thanks to the frontal solar module and to the back-up connections and circuits either side of the tanks, enabling them to be fitted side-by-side with the generator either in line, or at an angle with the back to the wall.

Delivered with DKSL 6-8 MSB solar station, SOL PLUS regulator, solar expansion vessel, mixing valve, three-way valve and sensor.



PREP\_C0001

## Main dimensions (mm and inches)

### ⇒ QUADRO SolarEasy 400

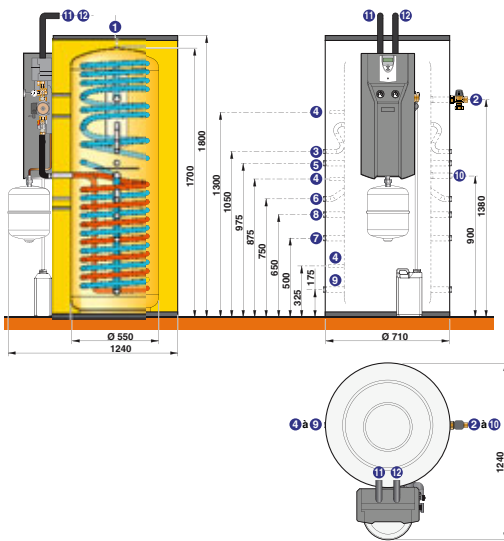

### ⇒ QUADRO SolarEasy 700

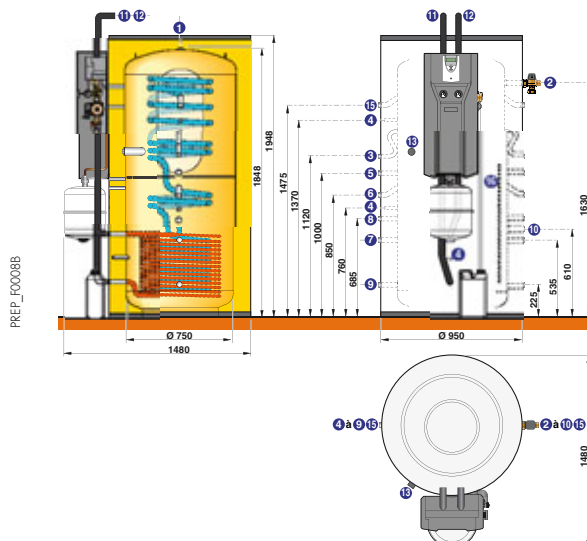

- ① Vent Rp 1/2"
- ② DHW outlet G1"
- ③ - SolarEasy 400: boiler outflows G3/4"
- SolarEasy 700: boiler heating circuits outflow G3/4"
- ④ Sensor tube, Ø16

- ⑤ Boiler DHW circuit return G1"
- ⑥ - SolarEasy 400: heating outflow G1"
- SolarEasy 700: heating circuit outflow G1"
- ⑦ Radiators return G1"
- ⑧ Boiler heating circuits return G1"
- ⑨ Underfloor heating return G1"

- ⑩ DCW inlet R1"
- ⑪ Solar return DN18
- ⑫ Solar outflow DN18
- ⑬ - SolarEasy 700: immersion heater position
- ⑭ - SolarEasy 700: boiler DHW circuit outflow
- ⑮ - SolarEasy 700: rules for external system sensor

## Table of specifications

Max. operating pressure: - primary circuit: 6 bar  
- secondary circuit (tank): 6 bar  
- DHW circuit: 7 bar

Max. operating temp.: - primary circuit: 110 °C  
- secondary circuit: 95 °C  
- DHW circuit: 95 °C

Model	QUADRO	SolarEasy 400	SolarEasy 700
Energy efficiency class		C	-
Total tank capacity	L	385	750
Connectable collector surface area	m <sup>2</sup>	8 (I2)	15 (I2)
Buffer tank capacity/DHW coil capacity	L	352/22	750/27
DHW coil exchange surface area	m <sup>2</sup>	4.3	4.3
Solar exchanger capacity	L	11	13
Solar exchange surface area		2.2	2.6
Domestic temperature set point	°C	55	55
Exchanged power at ΔT = 35 K for DHW preparation (in summer) (I)	kW	25	30
Hourly flow rate at ΔT 35 K (in summer) (I)	L/h	520	810
DHW storage temperature	°C	65	65
Flow rate in 10 mins at ΔT = 30 K (I)	L/10 mins	220	250
Back-up area maintenance consumption/Total volume maintenance consumption	kWh/24h	0.5/0.9	1.5/3.2
Weight empty	kg	105	170

(I) Cold water temp. 10 °C, storage temp. 65 °C, primary flow rate 2 m<sup>3</sup>/h. (I2) Minimum flow rate in summer with boiler and without solar input

## ⇒ Solar accessories for systems with BSL.. N + PS buffer tank (QUADROs come pre-equipped with solar accessories)

- SKS 13-45 solar station - Package ER665
- SOL PLUS regulator - Package ER709
- Solar circuit expansion vessel (6 bar - 120 °C): - 24 litres - Package EG118, 50 litres - Package EG83
- Wall attachment kit for expansion vessel up to 25 litres - Package EC118

- Heat-transporing fluid:
  - BIO premix (20 l) down to - 30 °C - Package ER316
  - high-performance premix (20 l) down to - 26 °C - Package EG100
  - standard premix (20 l) down to - 21 °C - Package EG101

NB: for a complete description of these accessories, please refer to pages 26 to 29.

# SYSTEMS: DHW PRODUCTION AND/OR HEATING BACK-UP

## ⇨ QUADRO SolarEasy system combined with an oil-fired boiler

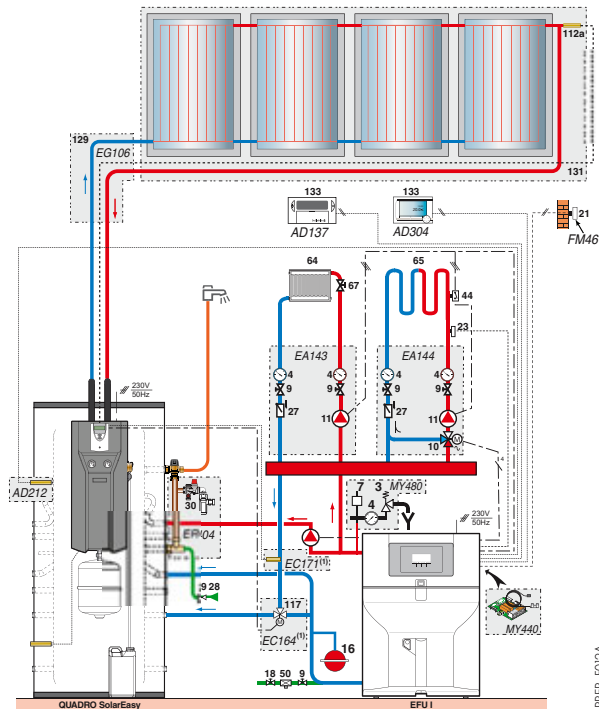

(I) Delivered with Quadro SolarEasy

This type of installation is suitable for new systems or renovations. QUADRO SolarEasy can be connected to any oil-fire or gas generator with a regulator able to manage 1 DHW production circuit and 1 or more heating circuits. It can be easily put in place on an existing installation if the DHW tank is replaced or when adding a solar system. The benefit of QUADRO SolarEasy is that it enables DHW production and provides heating back-up for the home or swimming pool with a greater collector surface area than with a CESI system.

### Operating principle

The collector field is connected to QUADRO SolarEasy via the solar station, managed by the SOL PLUS regulator, thanks to the lower sensor in the tank and the solar sensor in the collector field. The boiler is connected to the tank as follows:

- Heating circuit outflows to heating hydraulic modules or to the boiler's built-in circuit (EF/EFU E – equipped versions, for example),
- DHW outflow on the QUADRO top connection fitting,
- DHW return on the connection fitting 2/3 of the way up the QUADRO. Since the DHW sensor is positioned in the tank's upper sensor tube, the boiler will supplement DHW heating in the upper section of QUADRO.
- The heating returns will be directed either to the boiler return, or to the bottom of QUADRO, depending on whether the heating return temperature (sensor EC171) is greater or less than the QUADRO bottom temperature. The solar regulator manages the three-way valve (EC164, supplied) for the returns which enables solar input when required, or prevents QUADRO from being heated by the returns.

## ⇨ System with BSL 501 N (or B 802..) tank + PS buffer tank combined with a solid fuel boiler

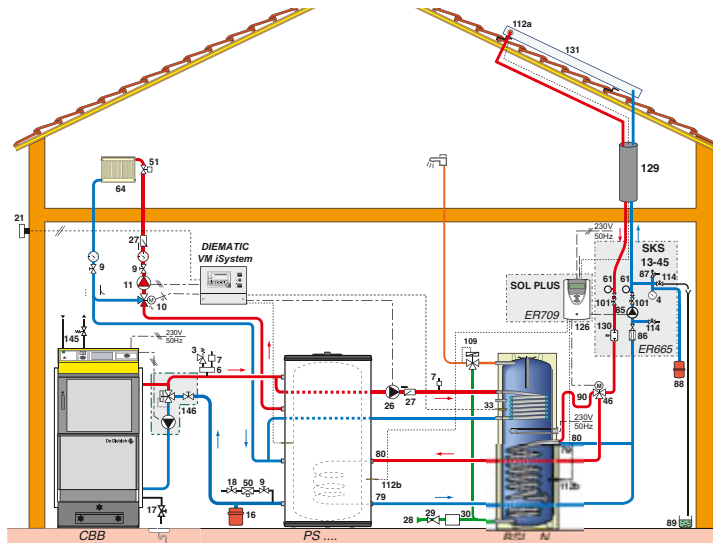

(I) With at least 8 m<sup>2</sup> of solar collectors

### Operating principle

The solar systems services 2 tanks, 1 buffer tank and 1 domestic hot water tank. This solution is adopted when you want to combine a solar system with a solid fuel boiler.

The SKS 13-45 solar station, supplemented by the SOL PLUS regulator, heats both tanks depending on the power supplied by the collectors, in order to use this energy wherever possible and most appropriate. The energy stored in the PS will be transferred to the BSL N via the back-up heat exchanger if there is no heating requirement and there is energy available.

## ⇨ Recommended solar collector/tank pairings

Solar collectors	Package no.	Number of people/Surface areas to heat			
		5 to 6 	7 to 8 	9 to 10 	10 to 12 
DH 200 (SL)	See pages 4 and 6	100 m <sup>2</sup>	150 m <sup>2</sup>	200 m <sup>2</sup>	> 200 m <sup>2</sup>
DHW tanks	QUADRO - 400				
	SolarEasy - 700	x	x		
	BSL 501 N + - PS 600 HR		x	x	
	- PS 1000 HR			x	x
B 802 HR + - PS 1000 HR	(AJ85 + AJ95) + (AJ61 + AJ89)				x

⇨ Solar accessories: see opposite page

# SOLAR ACCESSORIES FOR DOMESTIC INSTALLATIONS

## SOLAR STATIONS



Shown with SOL PLUS regulator (optional)

8990Q312

**DKSC 6 MSB solar station - Package ER711**  
 Double-circuit solar station for direct installation on BSL 150 N tank or wall mounting. For solar surface areas  $\leq 8 \text{ m}^2$ , solar pump manometric height: 7 mWc, Solar pump nominal output: 45 W.



8990Q305

**DKSL 6-8 MSB solar station - Package ER710**  
 Double-circuit solar station for direct installation on BSL/BESL 200 to 501 N tank or for wall mounting. For solar surface areas  $\leq 8 \text{ m}^2$ , solar pump manometric height: 7 mWc, Solar pump nominal output: 45 W.



8990Q310

**SKP 7-8 solar station - Package ER655**  
 Single-circuit solar station for direct installation on BSL/BESL.. N tank solar coils (3/4" connectors). For solar surface areas  $\leq 8 \text{ m}^2$ , solar pump manometric height: 7 mWc, Solar pump nominal output: 45 W.



SK\_Q0014

**SKS 13-45 solar station - Package ER665**  
 Double-circuit solar station for wall mounting only. For solar surface areas  $\leq 45 \text{ m}^2$ , solar pump manometric height: 13 mWc. Solar pump nominal output: 75 W.

These solar stations all comprise anti-thermosiphon valves, thermometers, isolating valves, manual air vent on degasser, filling and draining system, solar safety valve... The SKS 13-45 double-circuit solar station is also equipped with a flow rate indicator, enabling accurate calculation of the solar back-up on SOL PLUS regulators.

Solar pumps are modulating pumps, with energy efficiency index  $E_{EEI} < 0.23$ , suitable for high temperatures and the heat-transporting fluids. They are controlled to modulate their speed and flow rate by the SOL PLUS regulators via a PWM signal. All the stations can be installed on the insulating block of a SOL PLUS regulator. DKSC 6 MSB and DKSL 6-8 MSB stations can also be equipped with the SOL AEL regulator.

### Solar station pressure drops and solar pump specifications in relation with flow rate:

- DKCS 6 MSB, DKSL 6-8 MSB, SKP 7-8

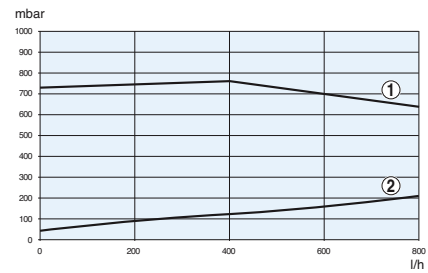

### - SKS 13-45

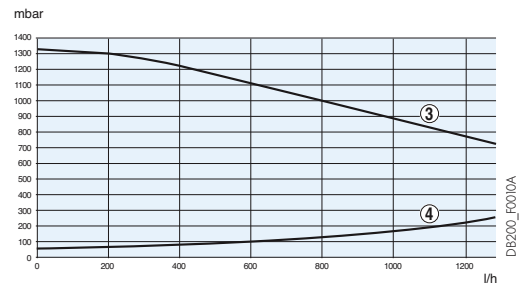

- ① Modulating solar pump manometric height: Wilos-Yonos PARA ST 15/7
- ② Solar station pressure drop: SKP 7-8, DKSL 6-8MSB, DKSC 6MSB
- ③ Modulating solar pump manometric height: Wilo-Yonos PARA ST 15/13
- ④ Solar station pressure drop: SKS 13-45

## Options for solar stations



8990Q240

**3/4" three-way valve with reversal motor - Package EC164**  
 For solar circuit with 2 tanks and SOL PLUS regulator.

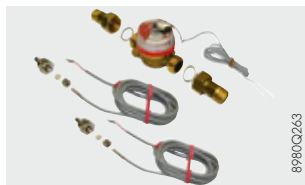

8990Q263

**Volumetric flowmeter - Package EC174**  
 Comprises a 3/4" flowmeter (nominal flow rate 1.5 m<sup>3</sup>/h) and 2 sensors. Enables accurate energy metering in solar installations.

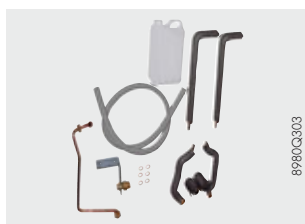

8990Q303

**Tubing kit for installing the DKSC 6 MSB station on the BSL 150 N tank - Package ER286**  
**Tubing kit for installing the DKSL 6-8 MSB station on the BSL 200 to 501 N tank - Package ER414**  
 Delivered with connection tubing for installing an 18 or 25 l solar expansion vessel.

## DUO-TUBES/DUO-FLEX

Using Duo-Tubes or Duo-Flex enables the solar collector/tank connection to be set up quickly, since they come with built-in insulation and sensor cable (insulation coefficient of Duo-Tubes and Duo-Flex:  $\lambda$  40 °C = 0.04 W/m<sup>2</sup>K).

**Benefits of Duo-Tubes:** generate low pressure drops, and facilitate solar circuit degassing.

**Benefits of Duo-Flex:** by virtue of their flexibility, easy to install under difficult conditions. The worm screw-shaped ribbed stainless steel is involved in degassing, and reduces pressure drops compared to a conventional hose.



**"Duo-Tube" kit Ø 10 mm x 10 m - Package ER319**  
**"Duo-Tube" kit Ø 15 mm x 10 m - Package EG106**  
**"Duo-Tube" kit Ø 15 mm x 15 m - Package EG107**  
 Comprises:

- Pre-insulated double Cu tubes, 15 x 10 m (EG106 and ER319), or 15 m (EG107) with UV protection and cable for collector sensor,
- 2 x DN 18 - DN 15 connectors, and 2 3/4" - DN 15 connectors, for connecting to the tank or solar station,

- 2 x 1/2" - DN 15 connectors for connecting to the solar collector,
- + for ER319: 4 DN15-DN10 reducers and 2 DN10-DN10 bicone connectors.

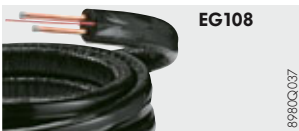

**Duo-Tube Cu 18 x 15 m - Package EG108**  
**"Duo-Tube" pre-insulated double tubes, with UV protection and cable for collector sensor**



**Duo-Flex kit Ø 16 x 15 m - Package EG422**

- Comprises:
- "Duo-Flex" pre-insulated double tubes, with UV protection and cable for collector sensor,
  - 2 DN18 - DN 16 connectors for connecting to the tank or solar station,
  - 2 x 1/2" connectors for the solar collector side connection.

### DuoTube/DuoFlex pressure drop:

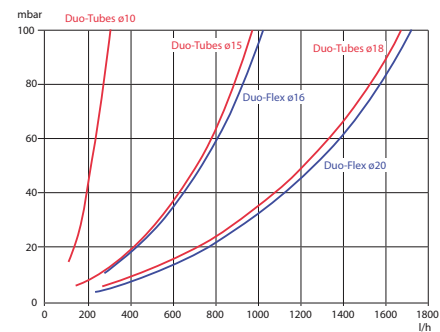

**Set of "Duo-Tube" or "Duo-Flex" collars**  
**For Duo-Tube Cu 15 and Duo-Flex Ø 16 mm, 4 pieces - Package EG109**



**Set of bicone connectors for connecting tanks to "Duo-Tubes" without brazing**  
**Set of 2 bicone connectors, Ø 15 mm - Package EG374**  
 For joining 2 Ø 15 mm "Duo-Tubes".  
**Set of 2 bicone connectors, Ø 18 mm - Package EG375**  
 For joining 2 Ø 18 mm "Duo-Tubes" or 2 Ø 18 mm tubes.

**For Duo-Tube Cu 18, x 4 m - Package EG110**

These connectors enable the solar circuit to be set up without brazing, as well as providing the connection between two Ø 15 or 18 mm tubes.



**Set of 2 bicone reducers, Ø 18/15 mm - Package EG376**  
 To be used with package EG375 (for connecting a tank to Ø 15 mm "Duo-Tubes" for example).

## EXPANSION VESSELS

The size of the expansion vessel depends mainly on the volume which can evaporate if the installation is shut down. Hence it will be determined depending on the number of collectors.

- Our CESI systems, as offered in our pricing catalogue, come with a built-in expansion vessel which meets the requirement under normal set-up conditions.
- For SSC systems, the choice of vessel is simple to make, as per the table opposite.

Collector inlet surface area	Length for pipes (flow & return) < 30 m	
	DH 200 (SL) CH 250 (SL)	POWER
< 10 m <sup>2</sup>	18 l	25 l
from 10 to 15 m <sup>2</sup>	25 l	35 l
from 15 to 20 m <sup>2</sup>	35 l	50 l

### Note:

The preloading pressure of the vessel and the installation pressure will need to be adapted depending on its particularities.

For SSC installations, we recommend placing the vessel on a tube of approximately 1 m, Ø 22 mm, to prevent direct contact with hot fluid.



**Solar circuit expansion vessel (6 bar - 120 °C):**

- 18 litres - Package EG117
- 24 litres - Package EG118

- 50 litres - Package EG83
- 80 litres - Package EG84

**Wall attachment kit for expansion vessel up to 25 litres - Package EC118**

# SOLAR ACCESSORIES FOR DOMESTIC INSTALLATIONS

## HEAT-TRANSPORTING FLUIDS

The heat-transporting fluid extracts the useful heat from the absorber and transfers it to the solar tank.



**BIO premix:** package ER316 (20 litres).  
This is a natural maize-derived product, which is biodegradable and has a 40% smaller ecological and energy footprint than glycol. With this product corrosion is better controlled (contains less acid). It is an AFSA-approved product, a very good antifreeze agent (down to - 30 °C) and highly resistant to high temperatures (up to 250 °C) and ageing.

**LS premix:** package EG100 (20 litres).  
**Standard premix:** package EG101 (20 litres).  
This is a mix comprising 43 % propylene glycol and 57 % water with protection from - 26 °C to + 160 °C for EG100, -21 °C to +160 °C for EG101

### Ageing resistance of fluids

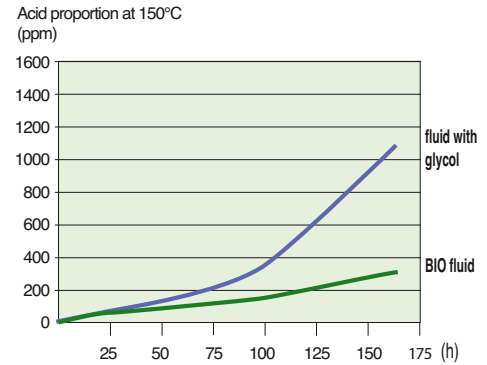

### Volume of fluid necessary for the installation

To determine the quantity of heat-transporting fluid, you need to calculate the overall volume of the installation. This is derived from the sum of the volumes of the collectors, the

solar exchanger, the solar station and the corresponding pipes. The expansion vessel preload should also be considered.

## SOLAR REGULATORS

SOL PLUS and SOL AEL are smart, autonomous regulators, which depending on the measured collector and tank temperatures, enable an optimum regulation (matched-flow) concept to be determined for the solar installation concerned. Once the installation has been flushed out and filled, they do not require any further calibration. SOL... regulators are characterised by their simple and clear use: the multi-purpose

display enables simultaneous reading of 2 temperatures; expressive pictograms inform the user particularly simply of the current mode and operating status. It has various connected sensors. Central control is provided via the 3 buttons situated under the display. SOL... regulators come factory-equipped with the INISOL solar system regulation program, and an approximate energy meter.

### Regulation principle

In automatic mode, SOL... regulators operate on the following principles:

- Solar radiation heats the heat-transporting fluid in the collector. To initiate the regulation process, the collector must reach a minimum temperature of 10 °C, and the collector/ tank difference must be at least 6 K.
- During the start-up phase, the solar pump is started up at 100 % speed.
- Thereafter, the solar pump fluctuates between 30 and 100 %, and continues loading the tank as long as the temperature difference between the collector and tank remains significant (factory setting 10 K).
- The tank will be loaded depending on the available heat until it reaches its storage temperature set point (factory setting 60 °C), and then the solar pump will be cut.

- If the sun continues to heat up and the collector reaches its maximum temperature (factory setting 110 °C), the solar pump will be reactivated in order to cool the system by 15 K below this value. If the tank temperature exceeds 95 °C, the solar pump will be shut down; the installation is overheated. The solar pump will be reactivated at night when the collectors temperature has fallen to cool the tank to the temperature set point (factory setting: 60 °C).
- The quantity of heat transferred from the collectors to the solar tank under normal operating conditions is counted by the regulator. To obtain an accurate measurement, the installation's various parameters must be recorded on the regulator (see installation manual).

### The various models available



**SOL PLUS - Package ER709**  
Designed for regulating solar installations with optimised loading of tanks equipped with 1 built-in heat exchanger. In addition, it has the "Solar First" solar priority function, preventing the back-up from operating once the solar pump has started. It can also manage a simple solar

**SOL AEL - Package ER708**  
Designed for regulating solar installations with just 1 tank and built-in exchanger. It incorporates the electrical back-up management functions, by means of daily heating programming in "back-up shutdown" or "boost"

system with 2 collector fields, 2 tanks with built-in exchanger or 1 tank + pool. It is delivered with 3 sensors, and can be integrated with all our DKSC/DKSL/SKP and SKS solar stations. SOL PLUS consumption: 1 W.

mode. It is delivered with 2 sensors. It can be integrated into DKSC 6 MSB and DKSL 6-8 MSB solar stations. SOL AEL consumption: 0.36 W.

## Choice of regulator depending on the solar system in place

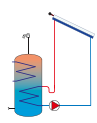
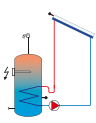
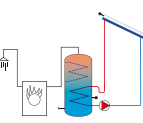
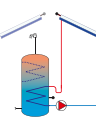
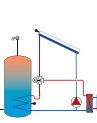
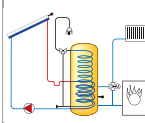
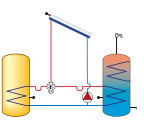
Regulator type	CESI installations				SSC installations		
							
<b>SOL PLUS</b>	yes	no	yes	yes	yes with EC164	yes with EC164	yes with EC164
+ regulation of a 2 <sup>nd</sup> collector field				yes with 2 <sup>nd</sup> pump (not supplied)	no	no	no
<b>SOL AEL</b> (with back-up management)	yes	yes	no	no	no	no	no
<b>Solar station to be combined</b>	DKSL 6-8 MSB DKSC 6 MSB	DKSL 6-8 MSB DKSC 6 MSB	DKSL 6-8 MSB DKSC 6 MSB	DKS 6-8 MSB* (ER710)  or SKP 7-8 (ER655)	DKSL 6-8 MSB* (ER710)  or SKS 13-45 (ER665)	DKSL 6-8 MSB* (ER710) built into QUADRO  or SKS 13-45 (ER665)	DKSL 6-8 MSB* (ER710)  or SKS 13-45 (ER665)

\* up to 8 m<sup>2</sup> of solar collectors.

## Options for solar regulators



PT 1000 dip sensor - Package EC173



PT 1000 probe sensor - Package EC171



Collector sensor - Package EC155



PWM connection kit for a 2<sup>nd</sup> solar pump - Package ER712

Enables a 2<sup>nd</sup> pump to be connected to the SOL PLUS regulator

(installations with 2 tanks or 2 EAST/WEST collector fields).



ModBus cable kit (3 m) - Package ER713

For connection between a SOL PLUS regulator and a control panel.



Lightning arrester unit for SOL... regulator - Package EC176

To be installed on the solar circuit by the collector.

## Other regulators



SLA 2 differential regulator - Package EC320

It is delivered with 2 sensors, and enables:

- the temperature of an independent tank combined with a boiler (no regulator), a buffer tank with boiler (no regulator), a buffer tank with wood boiler, or a solar buffer tank,
- monitor the heating return and bypass the solar tank if the return temperature is greater than the solar tank temperature.

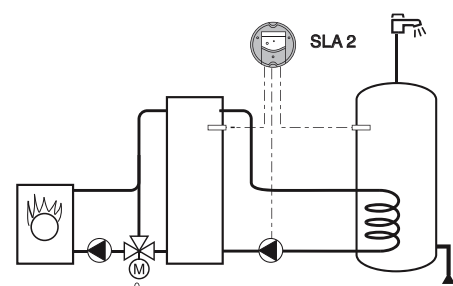

# COLLECTIVE SOLAR INSTALLATIONS FOR DHW PRODUCTION

Collective solar installations can be used for producing DHW and/or heating rooms, pools or heat networks. As for domestic

installations, there are various possible systems.

## DHW PRODUCTION SYSTEM WITH PREHEATING TANK AND A BUILT-IN HYDRAULIC BACK-UP DEVICE

- The simplest system is the one with **double-coil solar tanks with built-in back-up B 802/B 1002, or even BSL 501 N**. However, the connectable collector surface area is limited by the solar coil and by the DHW flow rate connected to the back-up boiler. So this system will be reserved for small collective installations.

- **Devices with independent back-up devices** are the most widespread: the back-up system may be a tank connected to a boiler, an electric or gas water heater, an individual back-up for each apartment.

### Technical specifications of B 802/B 1002 tanks with built-in hydraulic back-up (BSL 501 N: see page 16)

#### Description

High-performance solar domestic hot water tanks. Glass-lined food safe quality steel tank with double base, enabling the volume under the solar exchanger to be considered in order to obtain lower return temperatures. With a smaller solar exchanger and a second exchanger designed for connecting a boiler. Magnesium anode protection.

Drain opening and inspection hatch. Rigid casing (made from polyester fibres, thickness 120 mm, with polystyrene outer skin forming the casing) or flexible casing (fire rating M1, glass wool insulation, thickness 100 mm, with PVC outer skin).



RSB\_Q0004A

#### Main dimensions

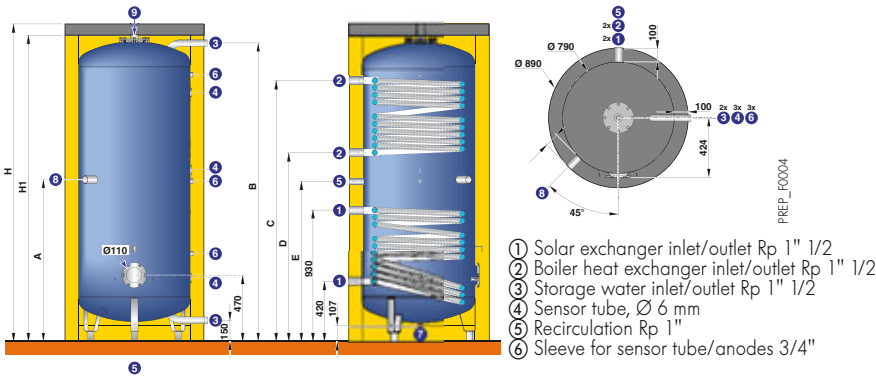

Type	B 802 HR	B 1002 HR
H	2 055	2 271
H1	1 955	2 171
A	976	1 147
B	1 889	2 115
C	1 542	1 847
D	1 134	1 337
E	1 024	1 133

- ⑦ Drain with plug R 3/4"
  - ⑧ Immersion heater end-fitting Rp 1" 1/2
  - ⑨ Domestic hot water outlet/vent Rp 2"
- Switch dimension: - B 802: 2010 mm  
- B 1002: 2220 mm

#### Table of specifications

##### Conditions of use:

Maximum operating temperature: - primary (exchanger): 95 °C  
- secondary (tank): 95 °C

Maximum operating pressure: - primary (exchanger): 12 bar  
- secondary (tank): 7 bar

Model	B 802				B 1002				
	L	800			1000				
Tank capacity	L	800			1000				
Back-up volume/Solar volume	L	310/490			350/650				
Heat exchanger		bottom (solar)		top (boiler)	bottom (solar)		top (boiler)		
Exchanger capacity	L	15.2	14.4	16.1	16.0				
Exchange surface area	m <sup>2</sup>	2	1.9	2.1	2.1				
Primary flow rate	m <sup>3</sup> /h	0.5	3	0.5	3				
Water pressure drop	mbar	-	150	-	135				
Primary inlet temperature	°C	50	70	70	80	50	70	70	80
Exchanged power (I) (2)	kW	4.5	12.5	29	39	4.8	13.2	32	43
Hourly flow rate (I) (2)	l/h	-	-	370	960	-	-	410	1050
Max. flow rate in 10 mins at ΔT 30 K (III)(3)	L/10 mins	-	-	420		-	-	465	
Heat loss coefficient UA (with HR casing)	W/K	2.12			2.43				
Shipping weight	kg	270			335				

(I) Cold water temp. 10°C (2) DHW temp. 45°C (3) DHW temp. 40°C, DHW storage temp. 65°C, values measured using the back-up volume only

#### Package list

	B 802	B 1002
Vessel	AJ85	AJ86
Rigid casing (HR)	AJ95	AJ97
Flexible casing (HS)	AJ115	AJ117

#### Options



6 kW/400 V shielded immersion heater, 1" 1/2 - Package AJ36



1/2" sensor tube (width 350 mm) - Package AJ162

Thermometer - Package AJ32

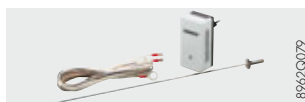

Impressed current anode - Package AM7

⇒ Recommended solar collector/tank pairings, BSL 501 N or B 802/1002

Tank		BSL 501 N	B 802	B 1002
Max. solar surface area per tank	m <sup>2</sup>	8.5	12.5	15
Number of CH 250 collectors (SL)		3	4-5	6-7
Solar dedicated volume	L	340	490	650

⇒ Example of installation

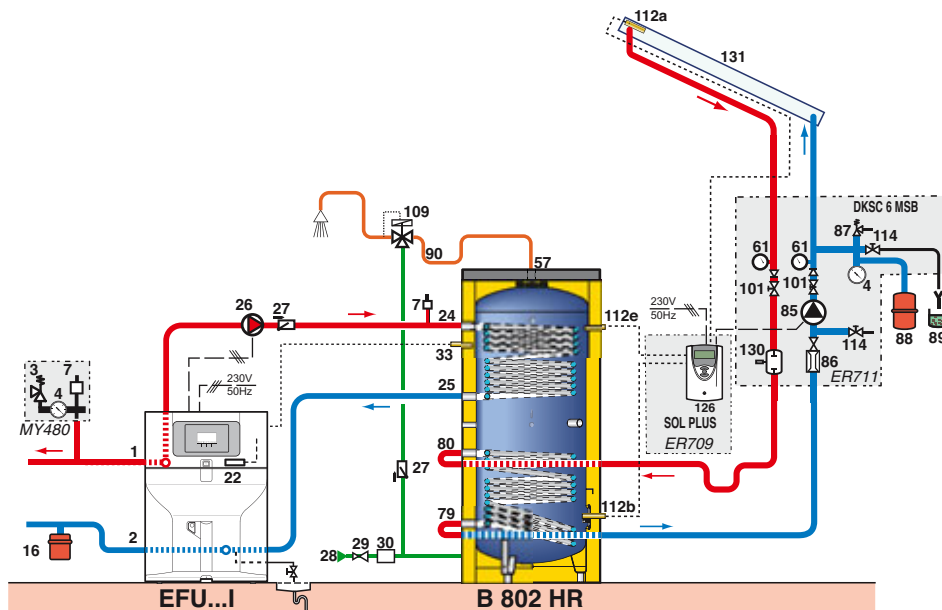

SOL\_10121

Operating principle

The solar circuit is connected to the tank lower coil via a solar station with its safety components, and is managed by a solar regulator. The circuit is filled with heat-transferring fluid, whether in pressurised or drain-back mode.

The solar tank is considered by the boiler as an independent tank whose temperature is maintained by the “DHW priority” function of the boiler control panel via the upper exchanger. If the solar energy is sufficient to produce domestic hot water at the desired temperature, the DHW priority of the boiler will remain inactive. If the solar energy is insufficient, the loading of the upper area of the tank will be supplemented by the boiler via the upper exchanger dedicated to it.

The solar tank may also be equipped with an immersion heater to achieve the DHW temperature should the solar energy be insufficient.

DHW tanks		BSL 501 N	B 802	B 1002
Hourly flow rate at $\Delta T = 35 \text{ K}$ (l)	L/h	590	960	1 050
Boiler min. useful power	kW	30	45	50

(l) Cold water temperature: 10 °C, DHW temperature: 45 °C, data for primary inlet temperature of 80 °C

⇒ Accessories for solar circuit

- DKSC 6 MSB solar station - Package ER711
- SOL PLUS regulator - Package ER709
- SOL AEL regulator - Package ER708 (for an additional electrical back-up)
- Solar circuit expansion vessel (6 bar - 120 °C): - 24 litres - Package EG118  
- 50 litres - Package EG83
- Heat-transferring fluid: - BIO premix (20 l) down to - 30 °C - Package ER316  
- high-performance premix (20 l) down to - 26 °C - Package EG100

NB: for a complete description of these accessories, please refer to pages 46 et seq.

# COLLECTIVE SOLAR INSTALLATIONS FOR DHW PRODUCTION

## DHW PRODUCTION SYSTEM WITH PREHEATING TANK AND AN INDEPENDENT BACK-UP DEVICE

### ↳ Technical specifications of B... HR/HS tanks to be equipped with an independent back-up device

#### Description

- Independent high-performance domestic hot water tanks,
- Glass-lined sheet steel tank, protection by magnesium anode,
- Coil-shaped glass-lined exchanger,
- **Rigid casing (HR)** made from polyester fibres, thickness 100 mm, with polystyrene outer skin,
- Side inspection hatch.



RSB\_Q0004A

#### Main dimensions

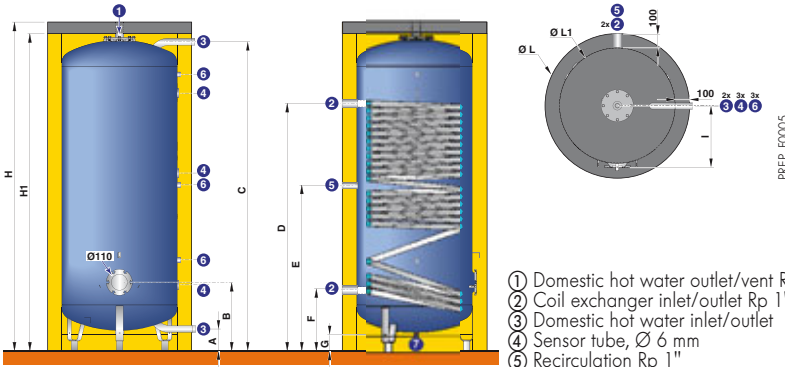

- ① Domestic hot water outlet/vent Rp 2"
- ② Coil exchanger inlet/outlet Rp 1" 1/2
- ③ Domestic hot water inlet/outlet
- ④ Sensor tube, Ø 6 mm
- ⑤ Recirculation Rp 1"
- ⑥ Sleeve for sensor tube/anodes 3/4"
- ⑦ Drain with plug R 3/4"

R: threading  
Rp: tapping

B...	H	H1	Ø L	Ø L1	A	B	C	D	E	F	G	I	Ø ③
650	1796	1696	990	790	150	470	1588	1338	869	420	107	425	R 1"1/2
800	2107	2007	990	790	150	470	1899	1338	1025	420	107	425	R 1"1/2
1000	2323	2223	990	790	150	470	2115	1695	1133	420	107	425	R 1"1/2
1500	2061	1961	1300	1100	150	502	1799	1542	975	452	59	584	R 1"1/2
2000	2292	2192	1300	1100	150	502	2040	1542	1095	452	59	584	R 1"1/2
2500	2086	1986	1600	1400	185	530	1740	1215	963	450	27	-	R 2"
3000	2248	2148	1600	1400	185	530	1902	1215	1044	450	27	-	R 2"

#### Table of specifications

##### Conditions of use:

Maximum operating temperature: - primary (exchanger): 110 °C  
- secondary (tank): 95 °C

Maximum operating pressure: - primary (exchanger): 12 bar  
- secondary (tank): 7 bar

Model	B... HR/HS	650	800	1000	1500	2000	2500	3000
Capacity	l	650	800	900	1505	1730	2500	2750
DHW coil exchange surface area	m <sup>2</sup>	4	4	4.4	5.5	5.5	5.5	5.5
Exchanger volume	l	30.4	30.4	33.4	41.8	41.8	41.8	41.8
Heat loss coefficient UA (HR)	W/K	2.5	2.8	2.9	3.4	3.8	4.1	4.6
Heat loss coefficient UA (HS)	W/K	2.7	3.0	3.2	3.8	4.4	4.6	4.8
↳ domestic performance (primary ΔT 15 K)								
Température départ chaudière	°C	70	70	70	70	70	70	80
Données à temp. sortie ecs 60 °C:								
- Max. exchanged power	kW	68	68	75	94	94	94	138
- Continuous flow rate	m <sup>3</sup> /h	1.2	1.2	1.3	1.6	1.6	1.6	2.4
- Exchanger pressure drop	mCE	1.2	1.2	1.5	2.9	2.9	2.9	6.1
Data at DHW outlet temp. 45 °C:								
- Max. exchanged power	kW	100	100	110	138	138	138	182
- Continuous flow rate	m <sup>3</sup> /h	2.5	2.5	2.7	3.4	3.4	3.4	4.5
- Exchanger pressure drop	mCE	2.4	2.4	3.0	6.1	6.1	6.1	10.2
Weight	kg	275	290	327	423	460	565	644
Cold water temp.: 10 °C								

Package list	B	650	800	1000	1500	2000	2500	3000
Vessel		AJ78	AJ79	AJ80	AJ81	AJ82	AJ83	AJ84
Rigid casing (HR)		AJ94	AJ95	AJ97	AJ99	AJ101	AJ103	AJ105
Flexible casing (HS)		-	AJ115	AJ117	AJ119	AJ121	AJ123	AJ125

#### Options

 1/2" sensor tube (width 350 mm) - Package AJ162

 Thermometer - Package AJ32

 Impressed current anode - Package AM7

 For B... tanks used as back-up  
Shielded immersion heater: - 9 kW/400 V mounted on DN 110 flange - Package AJ164  
- 15 kW/400 V mounted on DN 110 flange - Package AJ165  
- 30 kW/400 V mounted on DN 110 flange - Package AJ166

⇒ Solar collector/tank pairings, B 650 to 3000 (or even BLC 500), recommended for **pressurised systems**

Solar tank	B	650	800	1000	1500	2000	2500	3000
Max. solar surface area per tank	m <sup>2</sup>	13	13	15	18	20	23	25
Number of CH 250 collectors (SL)		5	5	6	7	8	9	10
solar circuit min. Ø	mm	18	18	18	18	22	22	28
Solar expansion vessel	L	50	50	50	50	50	80	80

⇒ Example of installation with B 650 to 3000 tank as back-up

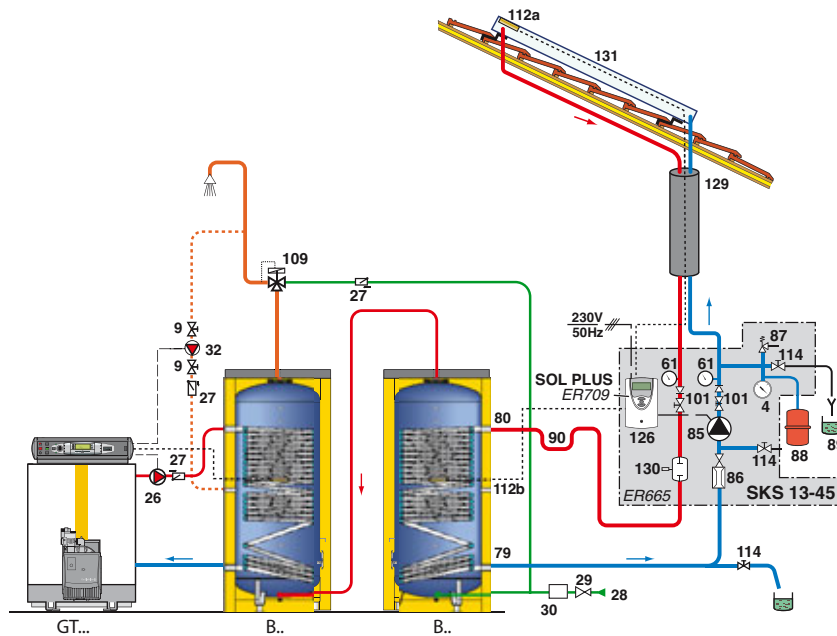

PREP\_F0250

### Operating principle

The solar circuit is connected to the tank coil via a solar station with its safety components, and is managed by a solar regulator. The circuit is filled with heat-transferring fluid. On the DHW circuit side, the solar tank is installed in series with a back-up tank whose temperature is maintained the DHW priority function of the boiler control panel via its exchanger, or by an immersion heater. The solar tank feeds the back-up tank with hot water depending on the energy received.

### Note:

- If the collector field is large, you need to:
- connect in parallel 2 collector fields to limit pressure drops in the solar circuit,
  - or use a solar station with plate heat exchanger to provide heat exchange.

A single solar circuit can feed 2 solar tanks heating alternately or simultaneously, depending on requirements.

Back-up tank		BLC 500	B 650	B 800	B 1000	B 1500	B 2000	B 2500	B 3000
DHW flow rate at 60 °C (primary at 80 °C)	m <sup>3</sup> /h	0.9	1.2	1.2	1.4	1.7	2.0	2.5	3
Boiler min. useful power	kW	60	65	65	70	90	90	90	90

### ⇒ Accessories for solar circuit

- **SKS 13-45 solar station** - Package ER665
- **SOL PLUS regulator** - Package ER709
- **Solar circuit expansion vessel (6 bar - 120 °C):**
  - 24 litres - Package EG118
  - 50 litres - Package EG83
  - 80 litres - Package EG84
- **Heat-transferring fluid:**
  - **BIO premix (20 l) down to - 30 °C** - Package ER316
  - **high-performance premix (20 l) down to - 26 °C** - Package EG100

**NB:** for a complete description of these accessories, please refer to pages 46 et seq.

# COLLECTIVE SOLAR INSTALLATIONS FOR DHW PRODUCTION

⇒ Solar collector/tank pairings, B 650 to 3000 (or even BLC 500), recommended for **Drain Back systems**

Solar tank		BLC 500	B 650	B 800	B 1000	B 1500	B 2000	B 2500	B 3000
Max. solar surface area per tank	m <sup>2</sup>	15	16	18	20	25	30	35	40
Number of CH 250 collectors (SL)		6	6	7	8	10	6 + 6	7 + 7	8 + 8
solar circuit min. Ø with H ≤ 25 m	mm	22	22	22	28	28	28	34	34

⇒ Example of installation with B 650 to 3000 tank as back-up

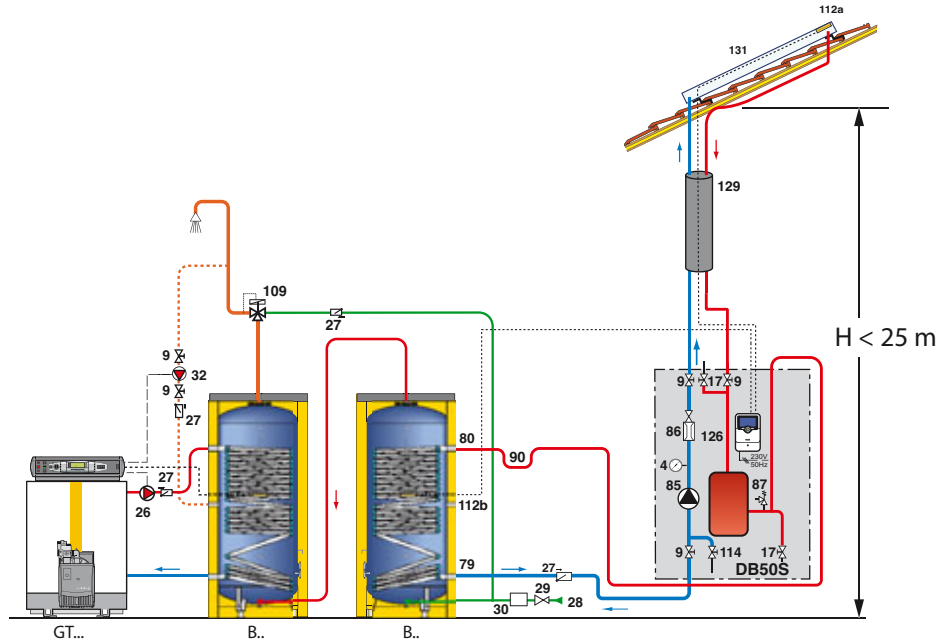

## Operating principle

The solar circuit is connected to the tank coil via a solar station with its safety components, and is managed by a solar regulator. The circuit is filled with heat-transferring fluid, whether in pressurised or drain-back mode.

On the DHW circuit side, the solar tank is installed in series with a back-up tank whose temperature is maintained the DHW priority function of the boiler control panel via its exchanger, or by an immersion heater. The solar tank feeds the back-up tank with hot water depending on the energy received.

## Note:

If the collector field is large, you need to:

- connect in parallel 2 collector fields to limit pressure drops in the solar circuit,
- or use a solar station with plate heat exchanger to provide heat exchange.

A single solar circuit can feed 2 solar tanks heating alternately or simultaneously, depending on requirements.

## ⇒ Accessories for solar circuit

- **DB 50 S solar station** - Package ER576
- **Heat-transferring fluid:** - **BIO premix (20 l) down to - 30 °C** - Package ER316
  - **high-performance premix (20 l) down to - 26 °C** - Package EG100
  - **standard premix (20 l) down to - 21 °C** - Package EG101

To protect the solar circuit pipes, we recommend using solar fluid with our Drain-Back systems.

We recommend using a mix with at least 10/15 % glycol in regions with no frost risk.

For other regions, the mix must maintain more than 30 % glycol. Mixes must be made with demineralised water.

**NB:** for a complete description of these accessories, please refer to pages 46 et seq.

⇒ Example of installation with independent back-up tank:

- CEB 500 electric water heater (see technical leaflet "Cor-Email/CES/CEB")
- RSB storage tank equipped with an immersion heater (for RSB specifications see pages 36 and 37)

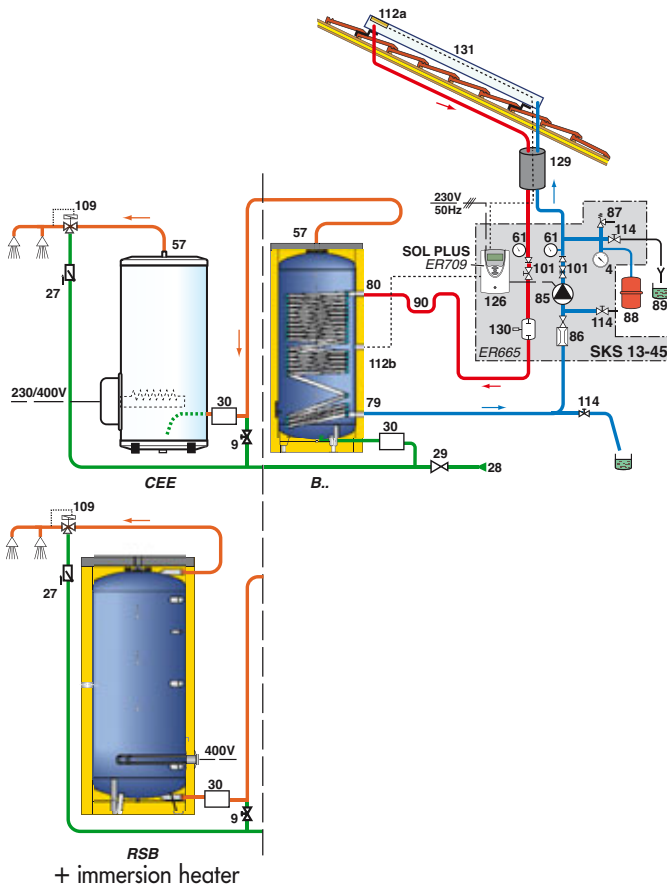

**Operating principle**

The solar circuit is connected to the tank coil via a solar station with its safety components, and is managed by a solar regulator. The circuit is filled with heat-transporting fluid, whether in pressurised or drain-back mode.

For the DHW circuit, the solar tank is connected upstream of the electric water heater or the RSB equipped with an immersion heater. It is this back-up which will ensure the desired DHW temperature if the sun is insufficient.





⇒ Accessories for solar circuit

- SKS 13-45 solar station - Package ER665
- SOL PLUS regulator - Package ER709
- Solar circuit expansion vessel (6 bar - 120 °C): - 24 litres - Package EG118  
- 50 litres - Package EG83  
- 80 litres - Package EG84
- Heat-transporting fluid: - BIO premix (20 l) down to - 30 °C - Package ER316  
- high-performance premix (20 l) down to - 26 °C - Package EG100

**NB:** for a complete description of these accessories, please refer to pages 46 et seq.

⇒ Heating time from 10 to 60 °C for back-up tanks equipped with an immersion heater

- CEB 500 tank with built-in 5 kW immersion heater: heating time: 6 h

Tank type		B	800	1000	1500	2000	2500	3000
 PREP_F0010	With shielded immersion heater (optional)	- 9 kW (package AJ164)	5 hrs 10	6 hrs 45	9 hrs 40	13 hrs	-	-
		- 15 kW (package AJ165)	3 hrs 05	3 hrs 55	5 hrs 50	7 hrs 45	9 hrs 45	11 hrs 35
		- 30 kW (package AJ166)	-	-	-	3 hrs 50	4 hrs 50	5 hrs 50
Tank type		B	802	1002				
 89900070	With shielded immersion heater (optional)		- 6 kW (package AJ36)	3 hrs 50	4 hrs 35			
Tank type		RSB	800	1000	1500	2000	2500	3000
 PREP_F0010	With shielded immersion heater (optional)	- 9 kW (package AJ164)	5 hrs 10	6 hrs 45	9 hrs 40	13 hrs	-	-
		- 15 kW (package AJ165)	3 hrs 05	3 hrs 55	5 hrs 50	7 hrs 45	9 hrs 45	11 hrs 35
		- 30 kW (package AJ166)	-	-	-	3 hrs 50	4 hrs 50	5 hrs 50
Tank type		RSB THS DN400	800	1000	1500	2000	2500	3000
 PREP_Q0008	With shielded immersion heater (optional)	- 9 kW (package AJ167)	5 hrs 10	6 hrs 45	9 hrs 40	13 hrs	-	-
		- 15 kW (package AJ168)	3 hrs 05	3 hrs 55	5 hrs 50	7 hrs 45	9 hrs 45	11 hrs 35
		- 30 kW (package AJ169)	-	-	-	3 hrs 50	4 hrs 50	5 hrs 50
 PREP_Q0007	With steatite immersion heater (optional)	- 9 kW (package AJ170)	-	6 hrs 45	9 hrs 40	13 hrs	-	-
		- 15 kW (package AJ171)	-	3 hrs 55	5 hrs 50	7 hrs 45	9 hrs 45	11 hrs 35
		- 30 kW (package AJ172)	-	-	-	3 hrs 50	4 hrs 50	5 hrs 50

# COLLECTIVE SOLAR INSTALLATIONS FOR DHW PRODUCTION

## DHW PRODUCTION SYSTEM

DIRECTLY ON A PREHEATING SOLAR TANK FEEDING THE DHW MAIN PRODUCTION SYSTEM

### ↳ Technical specifications of RSB... HR/HS storage tanks

#### Description

Glass-lined high-thickness steel DHW storage tank.  
High-performance glass coating specially tailored to the requirements of storing solar water, which may be at a very high temperature.  
Magnesium anode protection.  
DN 110 side inspection hatch.  
1" 1/2 end-fitting for immersion heater, optional.  
Bottom draining tank for easy cleaning.

Sensor holder for perfect positioning of sensors according to individual requirements.

Casing available in 2 versions:

- rigid casing (HR) made from polyester fibres, thickness 100 mm, with polystyrene outer skin,
- flexible casing (HS), fire rating M1, mineral wool insulation, thickness 100 mm, with PVC outer skin.



#### Main dimensions

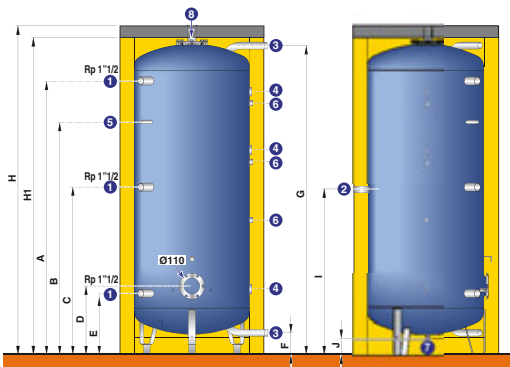

- ① ③ Domestic hot water inlet/outlet
  - ② Recirculation Rp 1"
  - ④ Sensor tube, Ø 6 mm
  - ⑤ Sensor tube 1/2" (thermometer)
  - ⑥ Sleeve for sensor tube / anodes 3/4"
  - ⑦ Drain with plug R 3/4"
  - ⑧ Domestic hot water outlet / vent Rp 2"
- R: threading  
Rp: tapping

RSB...HR	H	H1	Ø L	Ø L1	A	B	C	D	E	F	G	I	J	K	Ø ③
800	2055	1955	990	790	1629	1303	976	470	420	150	1899	1025	107	425	R 1"1/2
1000	2271	2171	990	790	1873	1593	1147	470	420	150	2115	1133	107	425	R 1"1/2
1500	2011	1911	1300	1100	1502	1302	1002	502	452	150	1799	975	59	584	R 1"1/2
2000	2252	2152	1300	1100	1740	1418	1096	502	452	150	2040	1095	59	584	R 1"1/2
2500	2033	2026	1600	1400	1446	1230	963	530	480	185	1740	963	27	733	R 2"
3000	2195	2098	1600	1400	1610	1339	1045	530	480	185	1902	1044	27	734	R 2"

#### Table of specifications

##### Conditions of use:

Maximum operating temperature: 95 °C

Maximum operating pressure: 7 bar

Model	RSB ... HR/HS	800	1000	1500	2000	2500	3000
Storage capacity	L	800	1000	1500	2000	2500	3000
Heat loss coefficient UA (HS casing)	W/K	1.91	2.22	2.60	3.31	3.76	4.25
Net weight	kg	255	265	340	372	450	541

Package list	RSB ... HR/HS	800	1000	1500	2000	2500	3000
Tank (Ø 110 mm inspection hatch)		AJ72	AJ67	AJ68	AJ69	AJ70	AJ71
Flexible casing (RSB...HR)		AJ95	AJ97	AJ99	AJ101	AJ103	AJ105
Flexible casing (RSB...HS) (fire rating M1)		AJ115	AJ117	AJ119	AJ121	AJ123	AJ125

#### Options

 1/2" sensor tube (width 350 mm) - Package AJ162

 Thermometer - Package AJ32

 Impressed current anode - Package AM7

For RSB... storage tanks used as back-up **only**:

 Shielded immersion heater mounted on DN 110 flange: - 9 kW/400 V - Package AJ164  
- 15 kW/400 V - Package AJ165  
- 30 kW/400 V - Package AJ166

## ⇨ Technical specifications of RSB... THS storage tanks, DN 400

### Description

Glass-lined high-thickness steel DHW storage tank.  
High-performance glass coating specially tailored to the requirements of storing solar water, which may be at a very high temperature.  
Magnesium anode protection.  
DN 400 side inspection hatch.  
Shielded immersion heater mounted on Ø 400 mm flange, optional.

Bottom draining tank for easy cleaning.  
Sensor holder for perfect positioning of sensors according to individual requirements.  
Flexible casing (HS), fire rating M1: comprising mineral wool insulation, thickness 100 mm, with PVC outer skin.



PREP\_G0006

### Main dimensions

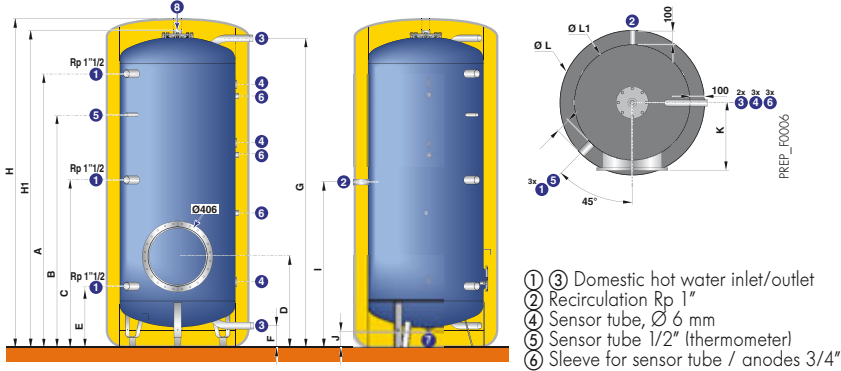

RSB...THS 400	H	H1	Ø L	Ø L1	A	B	C	D	E	F	G	I	J	K	Ø ③
1000	2271	2171	990	790	1873	1593	1147	623	420	150	2115	1133	107	465	R 1"1/2
1500	2011	1911	1300	1100	1502	1302	1002	655	452	150	1799	975	59	620	R 1"1/2
2000	2252	2152	1300	1100	1740	1418	1096	655	452	150	2040	1095	59	620	R 1"1/2
2500	2033	2026	1600	1400	1446	1230	963	683	480	185	1740	963	27	730	R 2"
3000	2195	2098	1600	1400	1610	1339	1045	683	480	185	1902	1044	27	730	R 2"

### Table of specifications

#### Conditions of use:

Maximum operating temperature: 95 °C

Maximum operating pressure: 7 bar

Model	RSB...THS 400	1000	1500	2000	2500	3000
Storage capacity	L	1000	1500	2000	2500	3000
Heat loss coefficient UA (HS casing)	W/K	2.52	2.90	3.61	4.06	4.55
Net weight	kg	260	340	375	450	540

Package list	RSB...THS 400	1000	1500	2000	2500	3000
Tank (Ø 406 mm inspection hatch - manhole)		AJ73	AJ74	AJ75	AJ76	AJ77
Flexible casing (RSB...THS DN400 HS) (fire rating M1)		AJ118	AJ120	AJ122	AJ124	AJ126

### Options

1/2" sensor tube (width 350 mm) - Package AJ162



8975G002

Thermometer - Package AJ32



8962G079

Impressed current anode - Package AM7

For RSB... storage tanks used as back-up **only**:



PREP\_G0008

Shielded immersion heater mounted on flange, Ø 400 mm: - 9 kW/400 V - Package AJ167  
- 15 kW/400 V - Package AJ168  
- 30 kW/400 V - Package AJ169

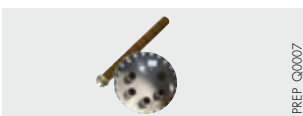

PREP\_G0007

Steatite immersion heater mounted on flange, Ø 400 mm: - 9 kW/400 V - Package AJ170  
- 15 kW/400 V - Package AJ171  
- 30 kW/400 V - Package AJ172

# COLLECTIVE SOLAR INSTALLATIONS FOR DHW PRODUCTION

⇒ Solar sensors/tank pairings recommended for **pressurised systems**

Solar tank	RSB	800	1000	1500	2000	2500	3000
Max. solar surface area per tank	m <sup>2</sup>	13	15	18	20	23	25
Number of CH 250 collectors (SL)		5	6	7	8	9	10
solar circuit min. Ø	mm	18	18	22	22	22	28
Solar station to be combined		STS 14-30	STS 14-30	STS 14-30	STS 14-30	STS 14-30	STS 14-30
Solar expansion vessel:							
- for requirements throughout the day	Package	EG83 (50 L)	EG83 (50 L)	EG83 (50 L)	EG83 (50 L)	EG83 (50 L)	EG83 (50 L)
- for evening requirements only	Package	EG83 (50 L)	EG83 (50 L)	EG83 (50 L)	EG83 (50 L)	EG84 (80 L)	EG84 (80 L)

Solar tank		2 x RSB 2000	2 x RSB 2500	2 x RSB 3000	3 x RSB 2500	3 x RSB 3000	4 x RSB 2500	4 x RSB 3000
Max. solar surface area per tank	m <sup>2</sup>	40	45	50	67	75	90	100
Number of CH 250 collectors (SL)		2 x 8	2 x 9	2 x 10	3 x 9	3 x 10	4 x 9	4 x 10
solar circuit min. Ø	mm	28	28	36	36	36	42	42
Collector field min. Ø	mm	22	22	28	22	28	22	28
Solar station to be combined		STS 14-50	STS 14-50	STS 14-50	STS 14-100	STS 14-100	STS 14-100	STS 14-100
Solar expansion vessel:								
- for requirements throughout the day	Package	EG84 (80 L)	EG120 (100 L)	EG120 (100 L)	EG122 (200 L)	EG122 (200 L)	EG123 (300 L)	EG123 (300 L)
- for evening requirements only	Package	EG120 (100 L)	EG120 (100 L)	EG122 (200 L)	EG122 (200 L)	EG123 (300 L)	EG123 (300 L)	EG123 (300 L)

⇒ Example of installation

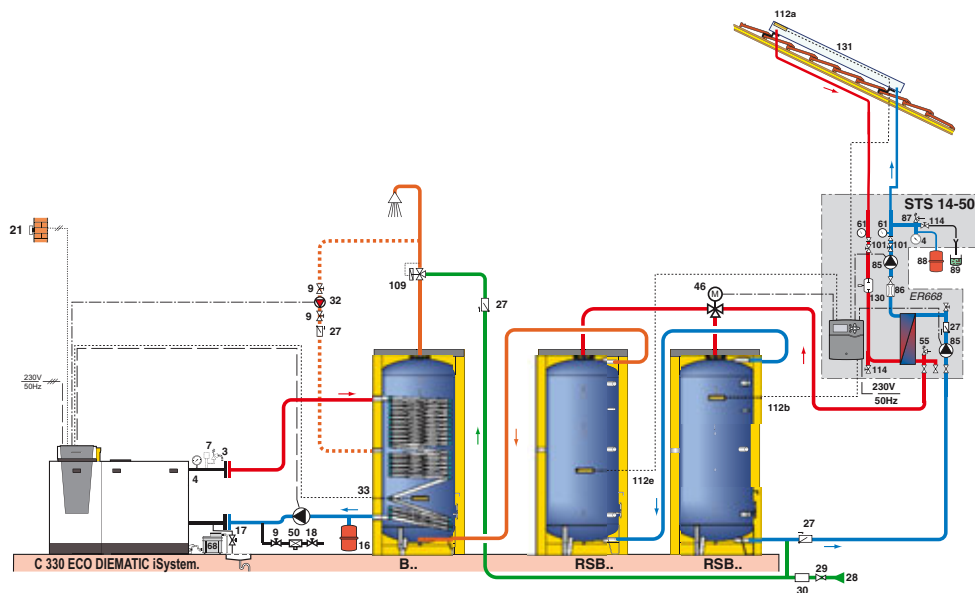

## Operating principle

The STS station enables DHW production directly from the solar circuit thanks to a high-performance plate heat exchanger built into the station. RSB tanks can store large quantities of domestic hot water. This domestic hot water

preheated the STS station can then be tapped off the RSB tanks to feed the main DHW production system (plate heat exchanger, electric tank, etc.), which must incorporate among other things an anti-legionella function.

⇒ Accessories for solar circuit

- **Transfer units:** - STS 14-30 CME - Package ER667  
 - STS 14-50 CME - Package ER668  
 - STS 14-100 CME - Package ER669
- **SOL SC. 5 regulator** - Package ER672
- **Solar circuit expansion vessel (6 bar - 120 °C):** - 50 litres - Package EG83  
 - 80 litres - Package EG84  
 - 100 litres - Package EG120  
 - 200 litres - Package EG122  
 - 300 litres - Package EG123
- **Heat-transporting fluid:** - BIO premix (20 l) down to - 30 °C - Package ER316  
 - high-performance premix (20 l) down to - 26 °C - Package EG100

NB: for a complete description of these accessories, please refer to pages 46 et seq.

⇒ **Solar sensors/tank pairings recommended for Drain Back systems**

Solar tank	RSB	800	1000	1500	2000	2500	3000
Max. solar surface area per tank	m <sup>2</sup>	13	15	18	20	23	25
Number of CH 250 collectors (SL)		5	6	7	8	9	10
solar circuit min. Ø	mm	28	28	28	28	28	28
Collector field min. Ø	mm	18	18	22	22	18	18
Max. height H	m	40	40	40	40	35	35
Combine with Drain Back unit		STSDB 50	STSDB 50	STSDB 50	STSDB 50	STSDB 50	STSDB 50

Solar tank		2 x RSB 2000	2 x RSB 2500	2 x RSB 3000	3 x RSB 2500	3 x RSB 3000	4 x RSB 2500	4 x RSB 3000
Max. solar surface area per tank	m <sup>2</sup>	40	45	50	67	75	90	100
Number of CH 250 collectors (SL)		2 x 8	2 x 9	2 x 10	3 x 9	3 x 10	4 x 9	4 x 10
solar circuit min. Ø	mm	28	35	35	35	42	42	42
Collector field min. Ø	mm	28	28	28	28	28	28	28
Max. height H	m	35	35	30	25	25	25	35
Combine with Drain Back unit		STSDB 50	STSDB 50	STSDB 50	STSDB 100	STSDB 100	STSDB 100	STSDB 150
- if the solar circuit volume is > the base unit tank volume (l)		-	STSDB 100	STSDB 100	STSDB 100	STSDB 150	STSDB 150	Make 2 solar circuits

(l) The actual capacity of the solar circuit determines the station to select. It must be less than the volume of the STDB unit.

⇒ **Example of installation**

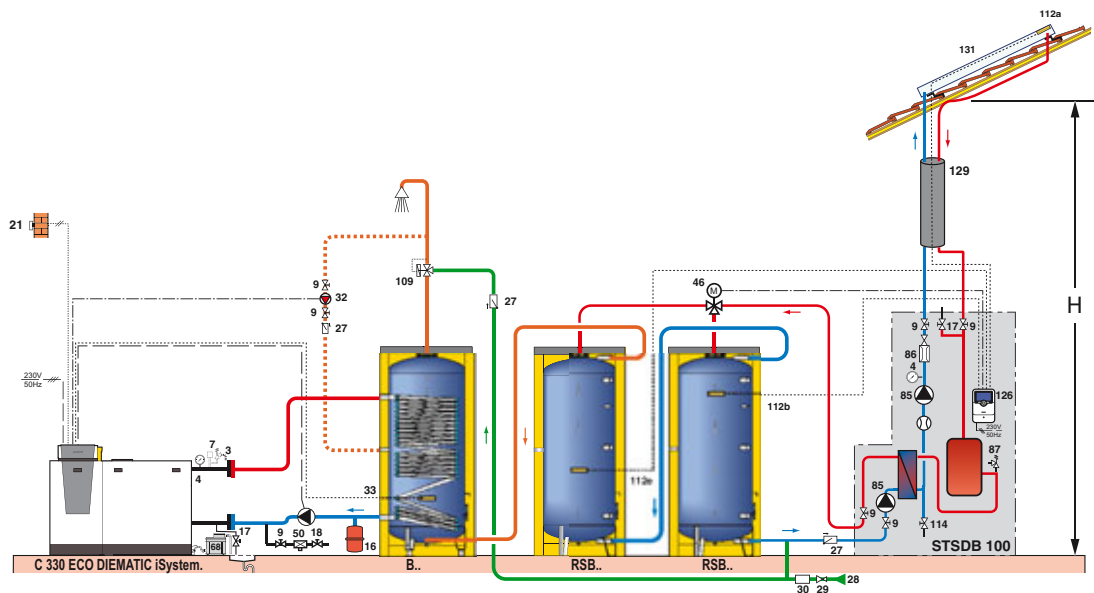

PREP\_F0351

**Operating principle**

The STS station enables DHW production directly from the solar circuit thanks to a high-performance plate heat exchanger built into the station. RSB tanks can store large quantities of domestic hot water. This domestic hot water

preheated the STS station can then be tapped off the RSB tanks to feed the main DHW production system (plate heat exchanger, electric tank, etc.), which must incorporate among other things an anti-legionella function.

⇒ **Accessories for solar circuit**

- **Solar stations:** - STSDB 50 - Package ER577  
- STSDB 100 - Package ER578  
- STSDB 150 - Package ER579
- **Heat-transporting fluid:** - BIO premix (20 l) down to - 30 °C - Package ER316  
- high-performance premix (20 l) down to - 26 °C - Package EG100  
- standard premix (20 l) down to - 21 °C - Package EG101

To protect the solar circuit pipes, we recommend using solar fluid with our Drain-Back systems.

We recommend using a mix with at least 10/15 % glycol in regions with no frost risk.

For other regions, the mix must maintain more than 30 % glycol. Mixes must be made with demineralised water.

**NB:** for a complete description of these accessories, please refer to pages 46 et seq.

# COLLECTIVE SOLAR INSTALLATIONS FOR DHW PRODUCTION

## INSTANT DHW PRODUCTION SYSTEM WITH SOLAR BACK-UP VIA A PS BUFFER TANK

### Technical specifications of PS buffer tanks

#### Description

- High-thickness sheet steel storage tanks, with a smooth tube exchanger welded into the tank in the upper part, for connecting to the solar installation
- The internal black anti-rust paint coating means that these tanks are aimed solely at producing and storing hot water for heating

- As well as the solar exchanger, the tank has multiple connection points for one or more boilers and heating circuits
- Casing available in 2 versions:
  - rigid casing (HR) made from polyester fibres, thickness 100 mm, with polystyrene outer skin
  - flexible casing (HS), mineral wool insulation, thickness 100 mm, with PVC outer skin, fire rating M1



RSB\_Q0004A

#### Main dimensions

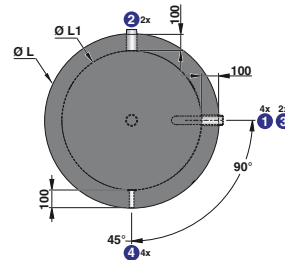
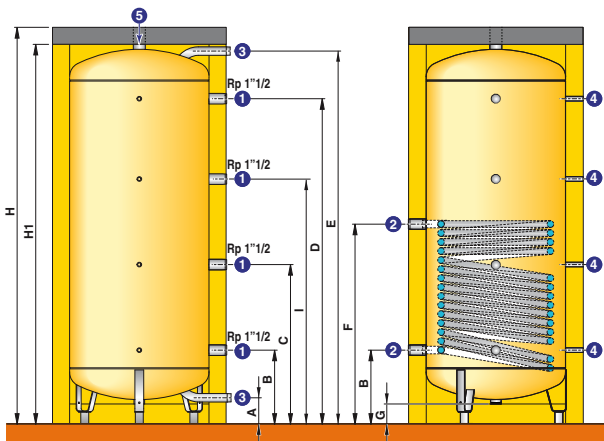

PREP\_E0002

- ① Storage water inlet
- ② Exchanger inlet/outlet Rp 1"1/2
- ③ Storage water outlet
- ④ Sleeve for sensor tube 1/2"

- ⑤ Storage water outlet / vent Rp 2"

R: threading  
Rp: tapping

PS...HR	Ø ③	PS...HR	H	H1	Ø L	Ø L1	A	B	C	D	E	F	G	I
600	R 1"1/2	600	2111	2011	830	630	150	420	852	1715	1985	981	128	1283
800	R 1"1/2	800	1940	1840	990	790	150	420	791	1532	1802	981	115	1161
1000	R 1"1/2	1000	2252	2152	990	790	150	420	905	1845	2114	1134	115	1390
1500	R 1"1/2	1500	1985	1885	1300	1100	150	452	800	1497	1799	962	67	1149
2000	R 1"1/2	2000	2226	2126	1300	1100	150	452	881	1738	2040	1064	67	1309
2500	R 2"	2500	2013	1913	1600	1400	187	480	802	1446	1740	990	17	1123
3000	R 2"	3000	2175	2075	1600	1400	187	480	856	1607	1902	990	17	1231

### Table of specifications

#### Conditions of use:

- Max. operating pressure: - tank: 6 bar
- exchanger: 12 bar

- Max. operating temperature: - tank: 95 °C
- solar exchanger: 95 °C

Model	PS ... HR/HS	600	800	1000	1500	2000	2500	3000
Capacity	L	550	750	1000	1500	2000	2500	3000
Exchanger volume	L	15.2	19.8	25.5	26.7	31.9	35.2	35.2
Max. size of heat exchanger/sensor surface	m <sup>2</sup>	2/10	2.6/12	3.8/16	3.5/15	4.2/18	4.6/20	4.6/20
Heat loss coefficient UA (HS casing)	W/K	1.45	1.78	2.22	2.60	3.31	3.76	4.25
Shipping weight	kg	160	190	220	340	420	505	535

Package list	PS ... HR/HS	600	800	1000	1500	2000	2500	3000
Vessel		AJ59	AJ60	AJ61	AJ62	AJ63	AJ64	AJ65
Rigid casing (HR)		AJ87	AJ88	AJ89	AJ90	AJ91	AJ92	AJ93
Flexible casing (HS)		AJ107	AJ108	AJ109	AJ110	AJ111	AJ112	AJ113

### Option



Thermometer - Package AJ32

89750002

⇒ Solar sensors/tank pairings recommended for **pressurised systems**

Solar tank	Type PS... HR/HS	600	800	1000	1500	2000	2500	3000
Max. solar surface area per tank	m <sup>2</sup>	10	12	16	18	20	23	25
Solar exchanger volume	L	15.2	19.8	25.5	26.7	31.9	35.2	35.2
Solar exchanger surface area	m <sup>2</sup>	2	2.6	3	3.5	4.2	4.6	4.6

⇒ Example of installation

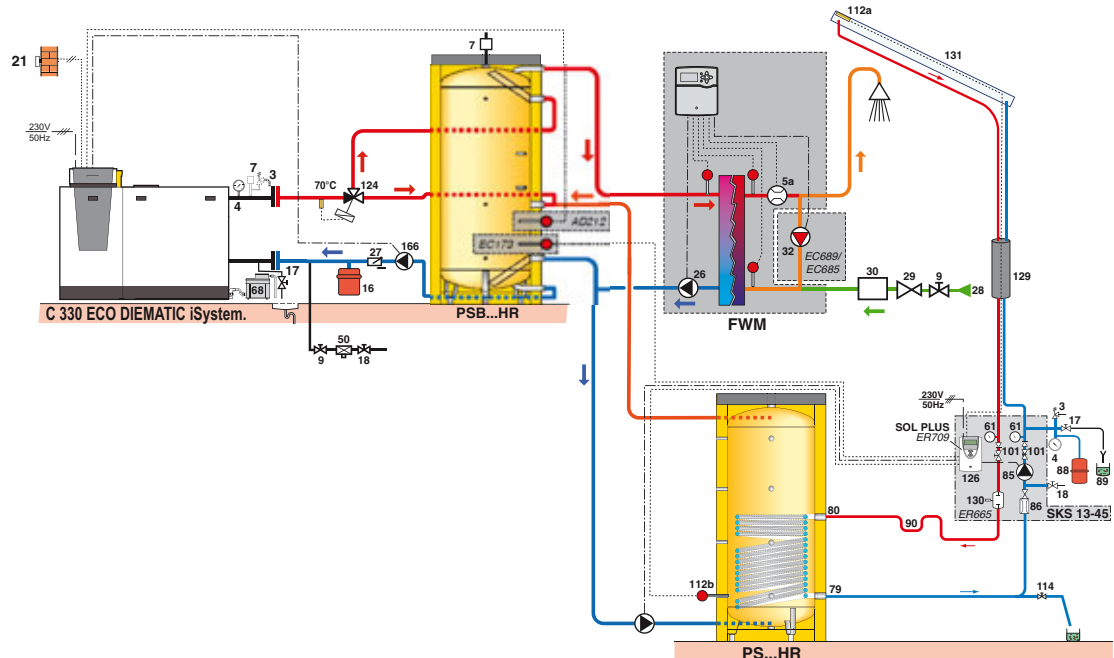

FWM\_F0004B

### Operating principle

The module or cascade of FWM modules are connected to the upper part of the buffer tank. At the FWM module outlet, a three-way valve directs the flow either to the buffer tank connected to the back-up boiler if the return temperature is greater than the temperature in the renewable energy back-up tank, or to the renewable energy tank if its temperature is less than the outlet temperature of the FWM modules to absorb the heat energy and transfer it to the boiler buffer.

It is the FWM regulator which controls the valve. For its part, the boiler will only top up the heating, ensuring at all times the temperature required for the FWM module to produce DHW in the necessary volume and at the necessary temperature.

⇒ Accessories for solar circuit

- SKS 13-45 solar station - Package ER665
- SOL PLUS regulator - Package ER709
- Solar circuit expansion vessel (6 bar - 120 °C):
  - 50 litres - Package EG83
  - 80 litres - Package EG84
  - 100 litres - Package EG120
  - 200 litres - Package EG122
  - 300 litres - Package EG123
- Heat-transporting fluid:
  - BIO premix (20 l) down to - 30 °C - Package ER316
  - high-performance premix (20 l) down to - 26 °C - Package EG100

**NB:** for a complete description of these accessories, please refer to pages 46 et seq.

# COLLECTIVE SOLAR INSTALLATIONS FOR DHW PRODUCTION

## INSTANT DHW PRODUCTION SYSTEM DIRECTLY FROM A SOLAR CIRCUIT

### Technical specifications of FWS.. instant DHW tanks

#### Description

- Tanks for instant domestic hot water production via an exchanger (double for FWS 1500)
- High-power DHW exchanger made from ribbed 1.4404 stainless steel to prevent scale deposits on the exchange surfaces, and ensure continual maintenance-free exchange
- Anti-rust coated steel tank for storing heating water, preventing boiler cycling in case of low water pressure

- Flexible polyester insulation, 100 mm thick, with semi-rigid outer skin
- The removable assembly for easy tank connection
- For use with a solar system, the tanks must be combined with an STS solar station with its regulator or a solar tank with built-in exchanger.



#### Main dimensions (mm and inches) FWS 750

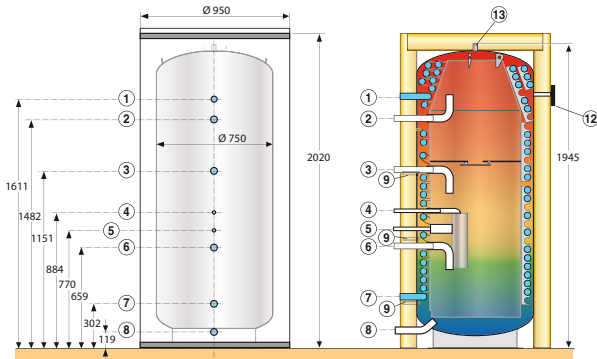

#### FWS 1500

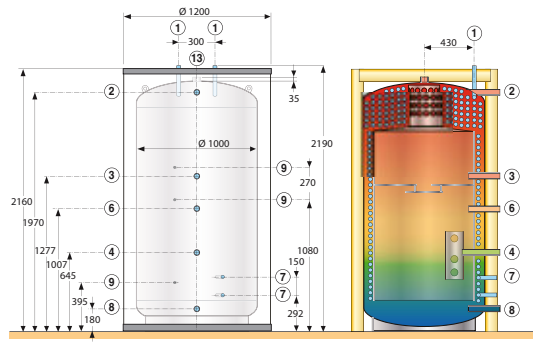

#### Legend

	FWS 750	FWS 1500
① Domestic hot water outlet	R 1 1/4	R 1
② Boiler inlet	R 1 1/4	R 1 1/2
③ Boiler return (max. solar)	R 1 1/4	Rp 1 1/2'
④ Solar circuit inlet	R 3/4	R 1 1/2
⑤ Solar extension volume inlet	R 3/4	-
⑥ Boiler return (min. solar)	R 1 1/4	Rp 1 1/2'

	FWS 750	FWS 1500
⑦ Domestic cold water inlet(s)	R 1 1/4	R 1
⑧ Solar circuit return/drain Boiler return if no solar circuit	R 1 1/4	R 1 1/2
⑨ Sensor tubes	20 mm	16 mm
⑫ Thermometer	Rp 1/2	-
⑬ Vent	Rp 1/2	R 2

### Table of specifications

#### Conditions of use:

- Operating pressure: - tank: 6 bar
- DHW exchanger: FWS 750: 7 bar
- FWS 1500: 10 bar

Maximum operating temperature: - tank: 95 °C

Model		FWS 750	FWS 1500
Total storage volume	L	700	1450
Max./min. solar storage volume	L	380/230	860/700
DHW coil capacity	L	52	104
DHW exchange surface area	m <sup>2</sup>	9.6 (single-coil)	14 (double-coil)
Max. exchanged power with solar back-up	kW	170	245
DHW coil pressure drops at 2 m <sup>3</sup> /h / 4 m <sup>3</sup> /h / 6 m <sup>3</sup> /h	bar	0.2/0.8/2.0	0.1/0.5/1.0
⇒ DHW flow rate at ΔT 35 K			
Continuous flow rate at ΔT = 35 K (primary at 80 °C) on min. back-up volume	L/h	4200	6000
Flow rate at ΔT 35 K in 10 mins (1) (2) with max. solar volume	L/10 mins	700	1000
⇒ DHW flow rate at ΔT 50 K			
Continuous flow rate at ΔT = 50 K (primary at 80 °C) on min. back-up volume	L/h	3000	3200
Flow rate at ΔT = 50 K in 10 mins (1) (2) with max. solar volume	L/10 mins	500	535
Heat loss coefficient (UA <sub>S</sub> )	W/K	4.1	9
Net weight	kg	260	320

(1) boiler connected at ② and ⑥ or ③ (with solar).

(2) cold water inlet temperature: 10 °C, DHW temperature: 45 °C, primary inlet temperature: 80 °C

#### Package list

	FWS 750	FWS 1500
Package no.	EC546	ER181 (tank) + ER182 (casing)

### Option



**DHW loop kit - Package ER29**  
Max. flow rate: 250 l/h (3 kW).

⇒ **FWS tank operating principle**

FWS tanks comprise a buffer tank with temperature stratification, equipped with injection nozzles and a high-performance coiled stainless steel exchanger incorporated into the tank for preparing domestic hot water (up to 80 L/min) (double exchanger for FWS 1500). Its design principle is based on division of the tank into 3 zones:

- ■ Zone 1: Hot water availability zone
- ■ Zone 2: Return and cold water zone
- ■ Zone 3: Additional DHW heating zone.

Smart loading technology, based on the thermosiphon principle, makes it possible to control the various operating zones selectively, and therefore optimise solar energy use. It is always the coldest water in the tank that will be introduced to the solar installation to be heated up. The “DHW heating zone”, operating with a reverse flow, during draw-off phases, ensures maximum cooling of the tank lower zone (cold water zone).

**Functional description**

⇒ **Loading the FWS... DHW tank**

Loading by modulating boiler with low-inertia exchanger (Al/Si, stainless steel or steel) + solar circuit

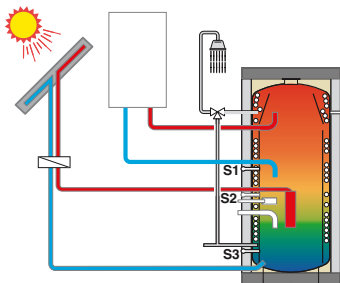

S1: DHW sensor  
S2: free  
S3: solar sensor

Loading by non-modulating boiler with high-inertia exchanger (cast iron) + solar circuit

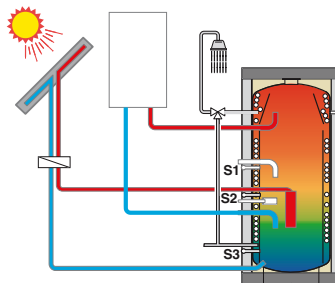

S1: free  
S2: DHW sensor  
S3: solar sensor

Loading by modulating boiler, solar circuit on tank with exchanger

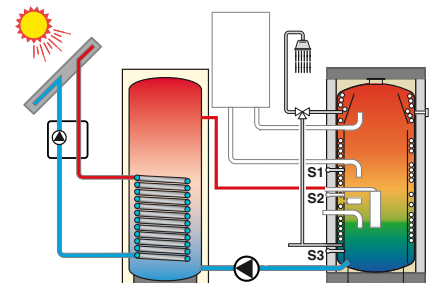

S1: DHW sensor  
S2: free sensor  
S3: solar sensor

⇒ **Recirculation loop on FWS...**

DHW loop via kit ER29 (optional - 250 L/h max.)

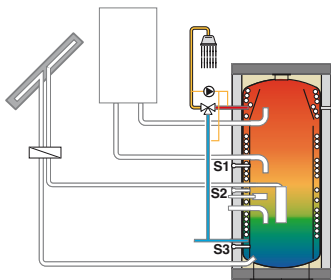

S1: DHW sensor  
S2: free  
S3: solar sensor

DHW loop via independent DHW tank (requirements > 250 L/h)

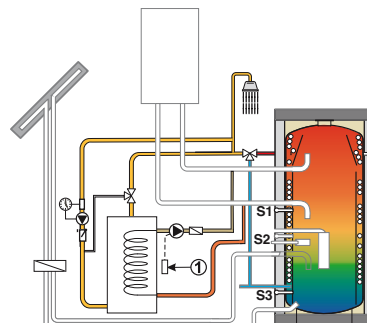

S1: DHW sensor  
S2: free  
S3: solar sensor  
①: thermostat 60 °C

DHW loop in the absence of solar circuit (on DHW inlet)

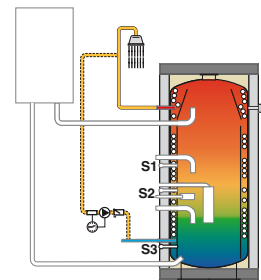

S1: free  
S2: free  
S3: DHW sensor

⇒ **Recommended solar collector/tank pairings**

Solar tank	Type	FWS 750	FWS 1500
Max. solar surface area per tank	m <sup>2</sup>	15	30
Solar volume	L	380	860

⇒ **Accessories for solar circuit**

- **Solar station:** - STS 14-30 CME - Package ER667  
- STS 14-50 CME - Package ER668
- **Solar circuit expansion vessel (6 bar - 120 °C):** - 80 litres - Package EG84  
- 100 litres - Package EG120  
- 200 litres - Package EG122
- **Heat-transferring fluid:** - BIO premix (20 l) down to - 30 °C - Package ER316  
- high-performance premix (20 l) down to - 26 °C - Package EG100

**NB:** for a complete description of these accessories, please refer to pages 46 et seq.

# COLLECTIVE SOLAR INSTALLATIONS FOR DHW PRODUCTION

## Installation examples With modulating boiler and solar circuit on external tank with exchanger

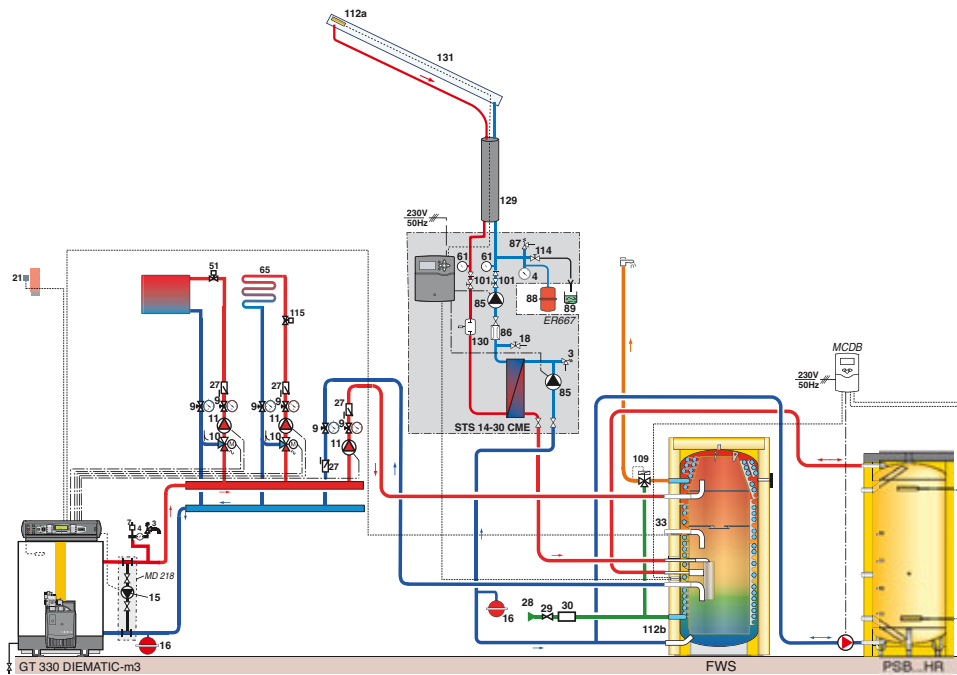

	FWS 750	1500
DHW flow rate at $\Delta t = 35\text{ K}$ (l/10 mins)	700	1 000
Continuous flow rate at $\Delta t = 35\text{ K}$ (l/h)	4 200	6 000
Cold water temp at $10\text{ }^\circ\text{C}$ , DHW temp. at $45\text{ }^\circ\text{C}$ , Primary temp. at $80\text{ }^\circ\text{C}$		

FW\_F0061

### Operating principle

The upper part (DHW) of the FWS can be loaded by cascaded boilers feeding the heating circuits and the DHW circuit connected to the heating manifold.  
The solar circuit is connected to the lower part of the tank to preheat the DHW. A heating circuit may be connected to the

bottom of the FWS for a pool for example, if solar energy is sufficient.

**Note:** to increase the storage volume, a PS tank may be connected in parallel to the FWS, with a booster pump and a MCDB regulator.

## With modulating boiler and solar circuit on the FWS

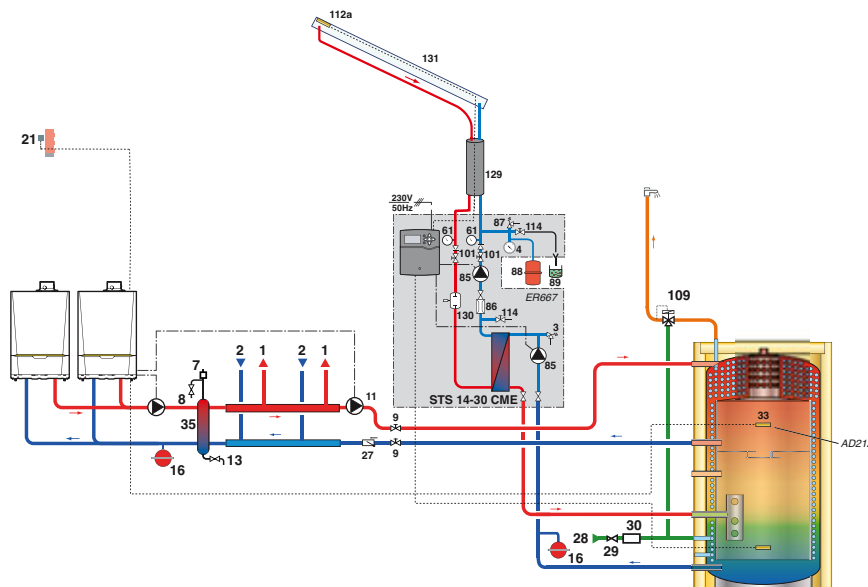

	FWS 750	1500
DHW flow rate at $\Delta t = 35\text{ K}$ (l/10 mins)	700	1 000
Continuous flow rate at $\Delta t = 35\text{ K}$ (l/h)	4 200	6 000
Cold water temp at $10\text{ }^\circ\text{C}$ , DHW temp. at $45\text{ }^\circ\text{C}$ , Primary temp. at $80\text{ }^\circ\text{C}$		

FW\_F0060

### Operating principle

The upper part (DHW) of the FWS can be loaded by cascaded boilers feeding the heating circuits and the DHW circuit connected to the heating manifold.

The solar circuit is connected to the lower part of the tank to preheat the DHW. A heating circuit may be connected to the bottom of the FWS for a pool for example, if solar energy is sufficient.

# SPECIFICATIONS OF PSB BUFFER TANKS

## ⇨ Technical specifications of PSB buffer tanks

### Description

High-thickness sheet steel storage tanks.  
Internal black anti-rust paint coating for producing and storing hot water for heating.  
Multiple connection points for one or more boilers and heating circuits.

Casing available in 2 versions:

- rigid casing (HR) made from polyester fibres, thickness 100 mm, with polystyrene outer skin,
- flexible casing (HS), mineral wool insulation, thickness 100 mm, with PVC outer skin, fire rating M1.



RSB\_G0004A

### Main dimensions

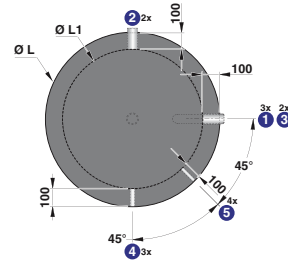
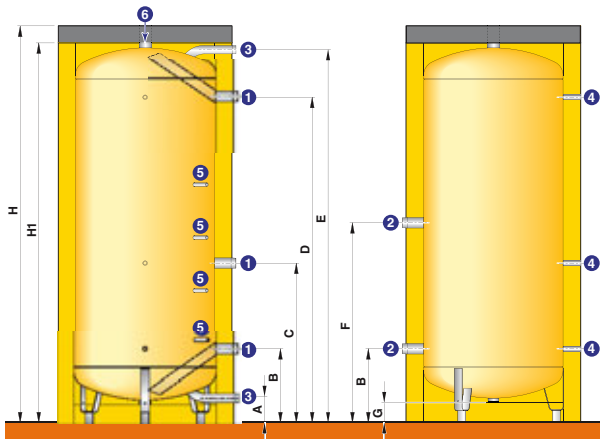

PREP\_F0001

- ① ② ③ Storage water inlet/outlet
- ④ Sleeve for sensor tube 1/2"
- ⑤ Sensor tube 1/2"
- ⑥ Storage water outlet / vent Rp 2"

- R: Threading
- Rp: Tapping
- G: Cylindrical ext. threading (sealed by sheet gasket)

PSB...HR	H	H1	Ø L	Ø L1	A	B	C	D	E	F	G	Ø ①②	Ø ③
600	2111	2011	830	630	1370	1120	820	250	1985	1713	852	R 1" 1/2	R 1" 1/2
800	1940	184	990	790	1250	950	650	470	1802	1532	790	R 1" 1/2	R 1" 1/2
1000	2253	2153	990	790	1350	1050	750	470	2115	1845	905	R 2"	R 1" 1/2
1500	1985	1885	1300	1100	1202	1003	702	502	1799	1497	804	R 2"	R 1" 1/2
2000	2226	2126	1300	1100	1452	1212	912	502	2040	1738	881	R 2"	R 1" 1/2
2500	2013	1913	1600	1400	1280	1040	740	530	1740	1445	790	R 2" 1/2	R 2"
3000	2175	2075	1600	1400	1280	1040	740	530	1902	1607	856	R 2" 1/2	R 2"

## Table of specifications

### Conditions of use:

Tank max. operating pressure: 5 bar

Tank max. operating temperature: 95 °C

Model	PSB...HR/HS	600	800	1000	1500	2000	2500	3000
Capacity	l	550	750	1000	1500	2000	2500	3000
Heat loss coefficient UA (IHS casing)	W/K	1.45	1.78	2.22	2.60	3.31	3.76	4.25
Shipping weight	kg	120	150	170	335	360	450	480

Package list	PSB...HR/HS	600	800	1000	1500	2000	2500	3000
Vessel	AJ52	AJ53	AJ54	AJ55	AJ56	AJ57	AJ58	AJ58
Rigid casing (HR)	AJ87	AJ88	AJ89	AJ90	AJ91	AJ92	AJ93	AJ93
Flexible casing (HS)	AJ107	AJ108	AJ109	AJ110	AJ111	AJ112	AJ113	AJ113

## Option



Thermometer - Package AJ32

89750002



MCDB regulator - Package EC162

Manages energy transfer from one buffer tank to another, and vice versa. It is delivered with 3 sensors.

89800275

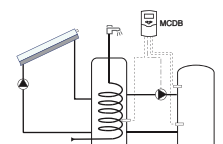

SOL\_F0065

# COLLECTIVE SOLAR INSTALLATIONS FOR DHW PRODUCTION

## COLLECTIVE SOLAR SYSTEMS WITH INDIVIDUAL SOLAR TANKS

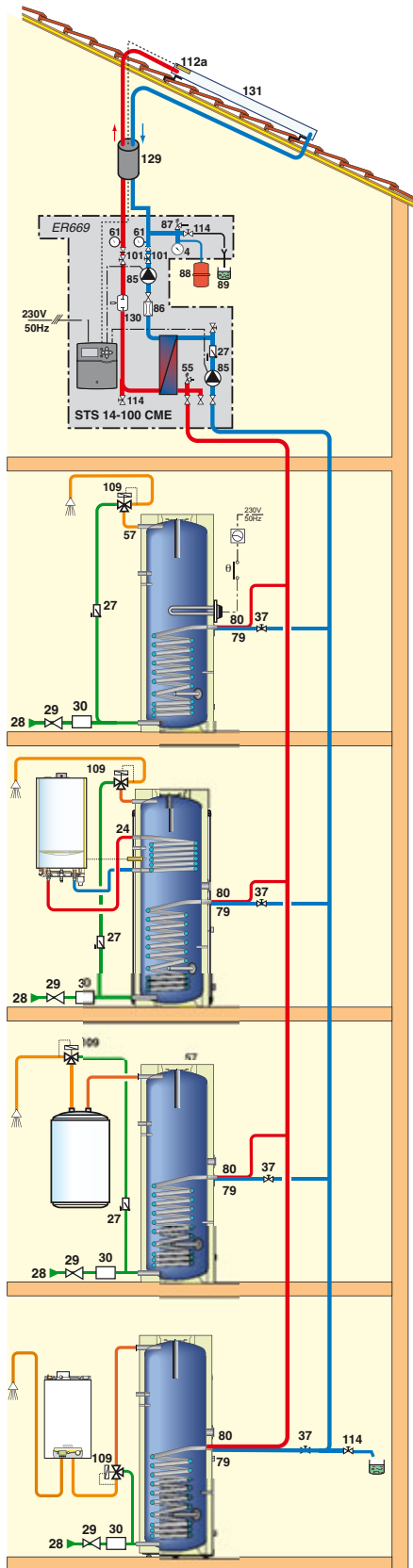

### Operating principle

Solar collectors in parallel feed a set of individual medium or small-capacity tanks. The collector field surface area must be suited to the number and nature of the tanks present in the installation, which are heated directly by the solar circuit.

The tanks may be located at various spots, such as in an apartment building where each home is equipped with an individual tank with its own back-up.

These tanks may be:

- double-coil tanks with a boiler as back-up,
- tanks without built-in back-up, serving an electric water heater or a double-service boiler (with instant DHW production).

Each tank must be balanced in relation to the installation as a whole via a balancing valve situated on the primary circuit return.

### Accessories for solar circuit

See pages 48 et seq.

## THERMOSIPHON SYSTEMS

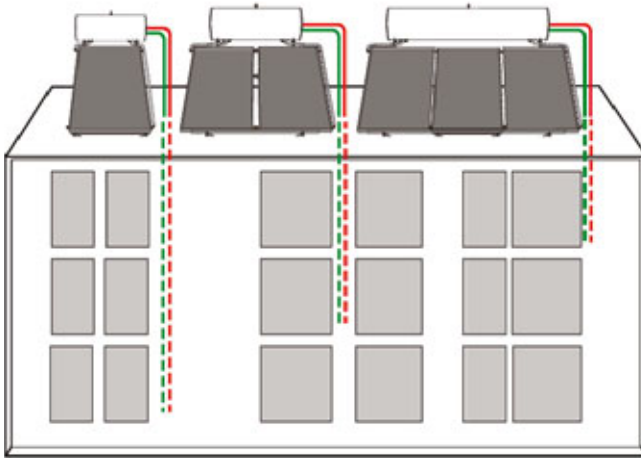

### Operating principle

The systems are installed individually on the roof or ground, and each one is individually connected to a network of 1 to x rooms or homes, depending on the requirement and the tank volume. The back-up can be directly built into the tank (immersion heater), or it can be external. The hot water outlet will in this case act as a cold water inlet for the back-up. You will need to ensure that the water distributed after the back-up is at an appropriate temperature. So a mixer absolutely must be installed at the tank outlet or the back-up outlet if it is external.

See STMO systems, page 22.

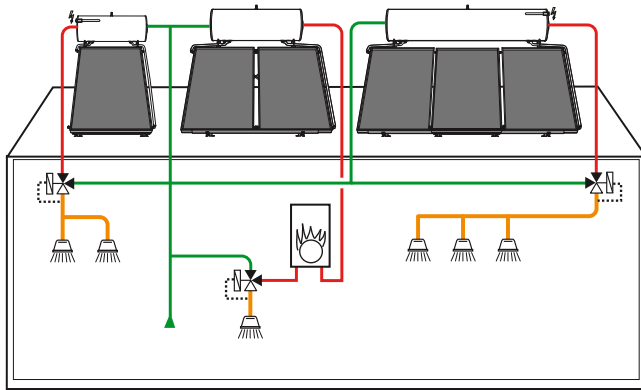

# SOLAR STATIONS/TRANSFER UNITS FOR

## SOLAR STATIONS FOR PRESSURISED SYSTEMS



### DKSC 6 MSB solar station - Package ER711

Double-circuit solar station for wall mounting.  
 - Solar pump manometric height: 7 mWc,  
 - Solar pump nominal output: 45 W.



### SKS 13-45 solar station - Package ER665

Double-circuit solar station for wall mounting only.  
 - Solar pump manometric height: 13 mWc.  
 - Solar pump nominal output: 75 W.

### Principle of solar stations

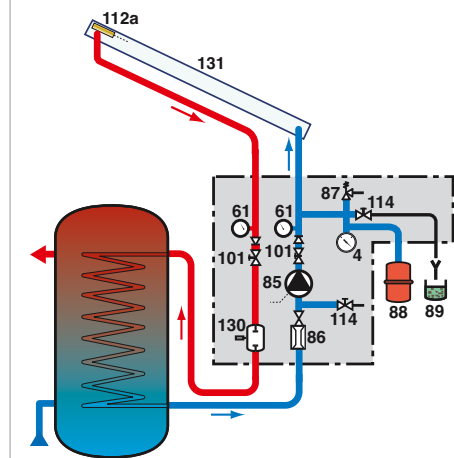

## Solar station pressure drops and solar pump specifications in relation with flow rate

### DKSC 6 MSB

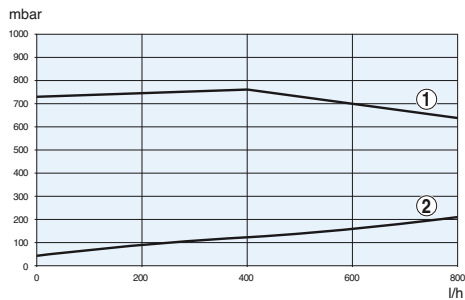

- ① Solar pump manometric height: Wilo-Yonos PARA ST 15/7
- ② Solar station pressure drop: DKSC 6 MSB

### SKS 13-45

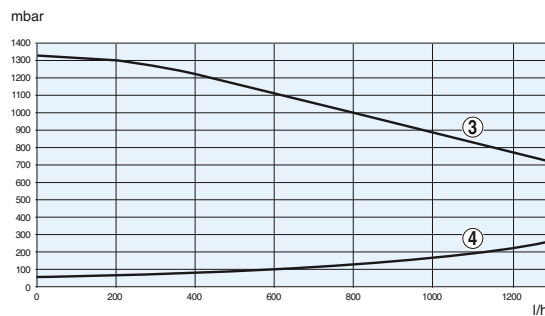

- ③ Solar pump manometric height: Wilo-Yonos PARA ST 15/13
- ④ Solar station pressure drop: SKS 13-45

These solar stations all comprise anti-thermosiphon valves, thermometers, isolating valves, manual air vent on degasser, filling and draining system, solar safety valve... The SKS 13-45 double-circuit solar station is also equipped with a flow rate indicator, enabling accurate calculation of the solar back-up on SOL PLUS regulators. Solar pumps are modulating pumps, with energy efficiency index  $EEl < 0.23$ , suitable for

high temperatures and the heat-transporting fluids. They are controlled to modulate their speed and flow rate by the SOL PLUS regulators via a PWM signal.

All the stations can be installed on the insulating block of a SOL PLUS regulator. The DKSC 6 MSB station can also be equipped with the SOL AEL regulator.



### Transfer units:

- STS 14-30 CME - Package ER667
- STS 14-50 CME - Package ER668
- STS 14-100 CME - Package ER669
- STS D 14-200 CME - Package ER670

↔ for installations containing more than 30 m<sup>2</sup> and up to 300 m<sup>2</sup> of flat collectors

Use: with solar tanks, **without** a solar exchanger incorporated.

### Design:

Factory-equipped with a "low flow" plate heat exchanger tailored to DHW and heating water, and a SOL SC5 solar regulator.

Also equipped with all the other components required for optimum operation of the installation: **see following pages.**

All these components: valves, pumps, etc. were sized to meet the operating requirements as per the "low flow" principle of De Dietrich's solar systems.

# COLLECTIVE INSTALLATIONS

## SOLAR STATIONS FOR DRAIN-BACK SYSTEMS



- Solar stations: - DB 50S - Package 576  
 - STSDB 50 - Package 577  
 - STSDB 100 - Package 578  
 - STSDB 150 - Package 579

These solar circuit energy transfer units are all delivered factory-assembled and tested in a sober and compact casing with easy access to all the components. They incorporate all the components necessary to ensure the correct operation, filling and maintenance of a self-draining collective solar installation, including:

- the heat-transporting fluid collection tank,
- the solar exchanger (except for version 50 S, which is directly connected to an immersed exchanger),
- the high water column solar pump with its variable speed drive, and the secondary pump for plate heat exchanger versions,

- the solar regulator (accessible remotely via DL3) for self-draining solar circuit management in "Variflow",

- the pipe with safety valve and separating valves for a single connection between the unit and the solar circuits and tank.

The station operates exclusively with heat-transporting fluid (10-30% mix) on a solar collectors circuit, enabling the fluid to return from the collectors to the transfer unit tank.

The exchanger and secondary circuit are designed for DHW or dead water production. They are equipped in plate heat exchanger versions with a flow meter energy metering system.

### Operating principle

Drain-Back solar installations prevent solar circuit overheating by removing the solar fluid from the collectors when the solar tank has reached its temperature set point. So they are auto-protected, ensuring the durability of the fluid.

However, they require precautions and know-how in installation, and are limited in terms of solar collectors/tank distance and height.

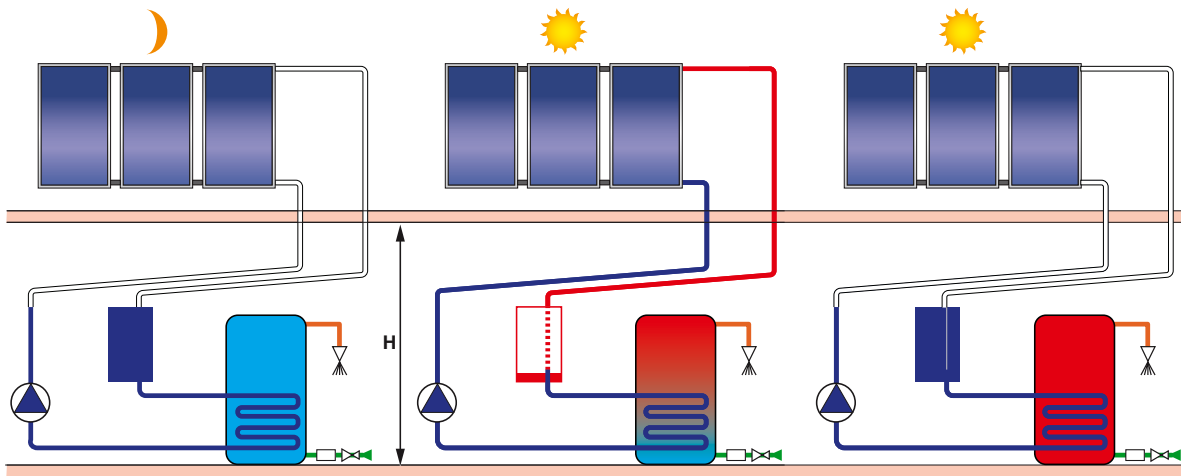

### Design

⇒ DB 50S

⇒ STSDB 50, 100 and 150

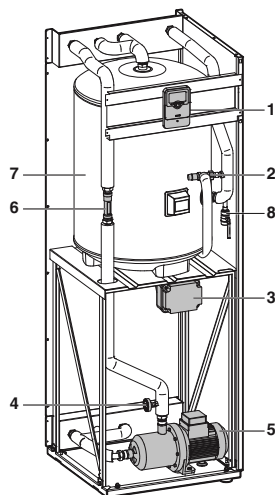

SOL\_F0036

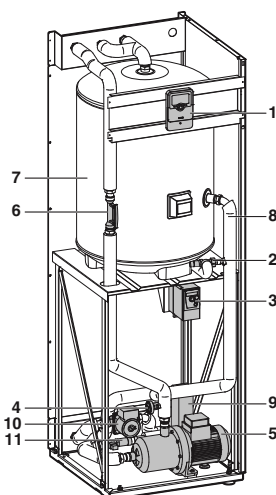

SOL\_F0037

### Legend

- |                          |                                |
|--------------------------|--------------------------------|
| ① Solar regulator        | ⑦ Solar storage volume         |
| ② Safety valve           | ⑧ Drain valve                  |
| ③ electric box           | ⑨ Plate heat exchanger         |
| ④ Pressure gauge         | ⑩ DHW circuit circulating pump |
| ⑤ Solar circulating pump | ⑪ Energy meter                 |
| ⑥ Flow rate regulator    |                                |

SOL\_F0050

# SOLAR STATIONS/TRANSFER UNITS FOR

## TECHNICAL SPECIFICATIONS OF SOLAR STATIONS/TRANSFER UNITS



SOL\_000006

	Solar station		Transfer unit				
	DKSC 6 - MSB	SKS 13 - 45	STS 14 - 30	STS 14 - 50	STS 14 - 100	STS D 14 - 200	
<b>Flat solar collectors:</b> For installations up to ... m <sup>2</sup> of solar collectors:							
- flat	m <sup>2</sup>	2 - 20	10 - 45	10 - 30	30 - 50	50 - 100	100 - 200
- tubular	m <sup>2</sup>	2 - 10	10 - 35	10 - 25	25 - 40	40 - 70	-
<b>Plate heat exchanger:</b>							
- type of plates		-	-	IC 8T-24	IC 25T-30	IC 25T-60	2 x IC 25T-60
- number of plates		-	-	24	30	60	2 x 60
- plate exchange surface area	m <sup>2</sup>	-	-	0.51	1.76	3.65	7.3
Exchanged power depending on the primary circuit flow rate and primary/secondary circuits temper- ature with 45 % glycol/water:							
- 15 L/h.m <sup>2</sup> at 60/40 °C	W/m <sup>2</sup> .°C	-	-	2080/2030	2030/1700	2040/1620	4080/3240
- 15 L/h.m <sup>2</sup> at 90/70 °C	W/m <sup>2</sup> .°C	-	-	2450/2390	2400/1980	2410/1910	4820/3720
- 20 L/h.m <sup>2</sup> at 60/40 °C	W/m <sup>2</sup> .°C	-	-	2840/2770	2780/2290	2795/2215	5590/4430
- 30 L/h.m <sup>2</sup> at 60/40 °C	W/m <sup>2</sup> .°C	-	-	3160/3080	3090/2550	3110/2460	6220/4920
Primary circuit and/or secondary circuit pressure drop at flow rate:							
- 15 L/h.m <sup>2</sup>	kPa	1.2	1.1	0.8	1.3	1.5	1.5
- 20 L/h.m <sup>2</sup>	kPa	2	1.9	1	1.95	2.05	2.05
- 30 L/h.m <sup>2</sup>	kPa	4	3.9	1.8	3.9	4.2	4.2
<b>Primary circulating pumps (230 V single):</b>							
- type		Yonos PARA ST15/7	Yonos PARA ST15/13	Solar PM2 15-145	Solar PM2 15-145	PML 25-145	2 x PML 25-145
- manometric height	mWc	7	13	14	14	14	14
- current consumption	A	0.45	0.7	0.7	0.7	1.1	2.1
- power consumption	W	3 - 45	4 - 75	7 - 70	7 - 70	3 - 140	6 - 280
<b>Secondary circulating pumps (230 V single):</b>							
- type		-	-	UPM2 15-75	UPM2 15-75 CIL	UPML 25-105	2 x UPML 25-105
- manometric height	mWc	-	-	8	8	11	11
- current consumption	A	-	-	0.7	0.7	1.16	2.32
- power consumption	W	-	-	7 - 70	7 - 70	6 - 140	12 - 280
<b>Equipment:</b>							
Combine with solar tanks		BLC 400 and 500	BLC 400 and 500	FWS 750, 1500	FWS 1500	-	-
		B 802 and B 1002	B 802 and B 1002	B 600 to 3000	B 600 to 3000	B 600 to 3000	B 600 to 3000
		B 650 to 3000	B 650 to 3000	RSB 650 to 3000	RSB 650 to 3000	RSB 650 to 3000	RSB 650 to 3000
		PS 550 to 3000	PS 550 to 3000	PS 600 to 3000	PS 600 to 3000	PS 600 to 3000	PS 600 to 3000
		-	-	PSB 600 to 3000	PSB 600 to 3000	PSB 600 to 3000	PSB 600 to 3000
Combine with regulator		<b>Option</b> Sol Plus (see p. 62)	<b>Option</b> Sol Plus (see p. 62) Sol SC5 (see p. 62)	<b>Included</b> Sol SC5 (see p. 62)	<b>Included</b> Sol SC5 (see p. 62)	<b>Included</b> Sol SC5 (see p. 62)	<b>Included</b> Sol SC5 (see p. 62)
Combine with energy meter:							
- solar		Package EC174 (see p. 63)	Package EC174 (see p. 63)	<b>Included</b>	<b>Included</b>	<b>Included</b>	<b>Included</b>
- system		CME + meters	CME + meters	CME + meters	CME + meters	CME + meters	CME + meters

# PRESSURISED SYSTEMS IN COLLECTIVE INSTALLATIONS

## HYDRAULIC SCHEMATIC DIAGRAMS OF TRANSFER UNITS

STS 14-30 CME

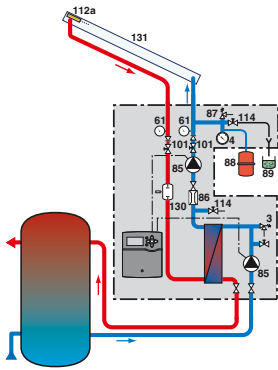

SOL\_F0046

STS 14-50 CME  
STS 14-100 CME

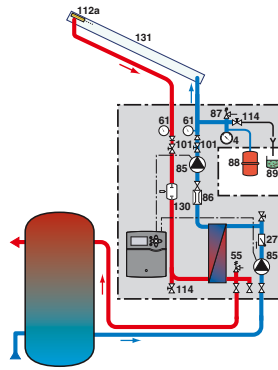

SOL\_F0047

STS D 14-200 CME

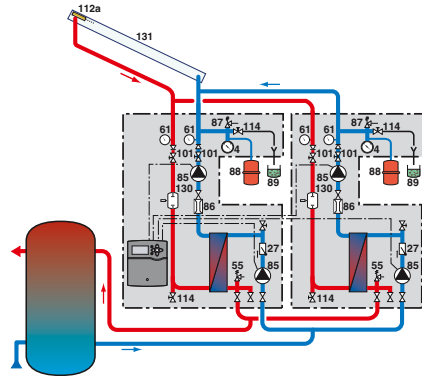

SOL\_F0048

## SOLAR STATION PRESSURE DROPS AND MANOMETRIC HEIGHTS OF SOLAR PUMPS IN RELATION WITH FLOW RATE / SPECIFICATIONS IN PRIMARY/SECONDARY CIRCUITS

↳ Solar primary circuit  
STS 14-30 CME

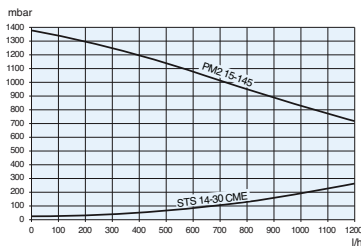

SOL\_F0200

STS 14-50 CME

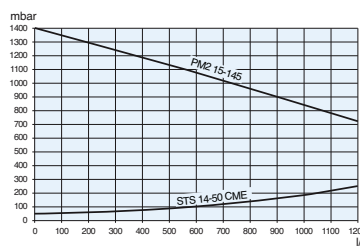

SOL\_F0202

STS 14-100 CME  
STS D 14-200 CME

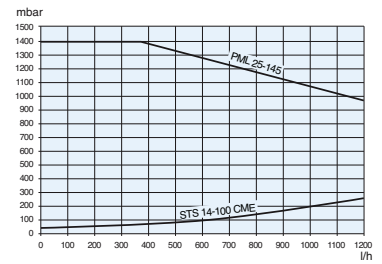

SOL\_F0201

↳ Domestic water circuit  
STS 14-30 CME

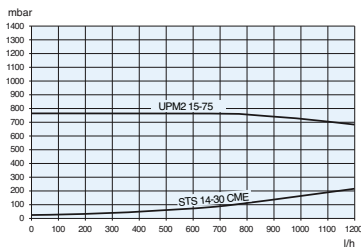

SOL\_F0250

STS 14-50 CME

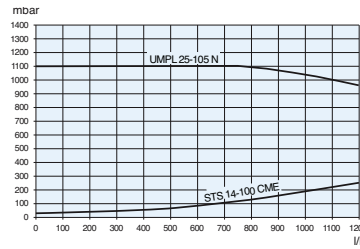

SOL\_F0252

STS 14-100 CME  
STS D 14-200 CME

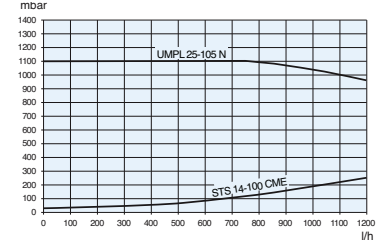

SOL\_F0251

### Dimensions:

	STS 14-50CME	STS 14-100CME
A	795	829
B	120	220

- Connector Ø for expansion vessel: ext. G 3/4  
- Safety valve outlet Ø: int. G 3/4

STS 14-30 CME

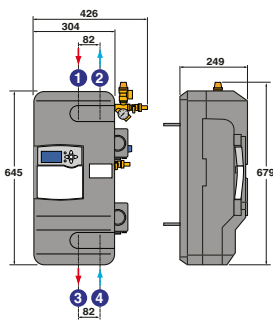

SOL\_F0055

STS 14-50 CME, STS 14-100 CME

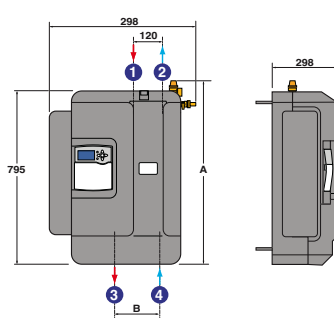

SOL\_F0056

STS D 14-200 CME

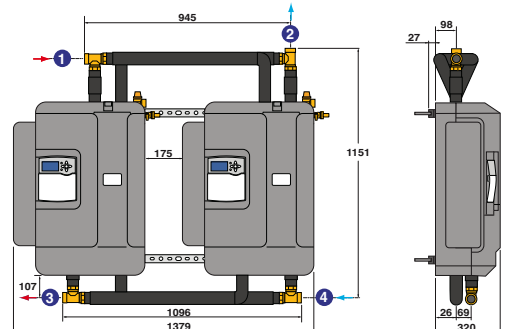

SOL\_F0057

### Common legend

	STS ... CME	14-30	14-50	14-100	14-200
①	Solar circuit outflow Ø	Int. G 3/4"	Int. G 3/4"	Int. G 1"	Ext. G 2"
②	Solar circuit return Ø	Int. G 3/4"	Int. G 3/4"	Int. G 1"	Ext. G 2"
③	Outflow to buffer tank Ø	Int. G 3/4"	Ext. G 1"	Ext. G 1" 1/4	Ext. G 1" 1/2
④	Buffer tank return Ø	Int. G 3/4"	Ext. G 1"	Ext. G 1" 1/4	Ext. G 1" 1/2

# SOLAR STATIONS/TRANSFER UNITS FOR

## TECHNICAL SPECIFICATIONS OF SOLAR STATIONS/TRANSFER UNITS



SOL\_000006

		Solar station DB 50 S	STS DB 50	Transfer unit STS DB 100	STS DB 150
<b>Flat solar collectors:</b> For installations up to ... m <sup>2</sup> of flat solar collectors	m <sup>2</sup>	10 - 40	30 - 50	40 - 100	60 - 140
<b>H:</b> building max. height	m	25	34	25	30
<b>Plate heat exchanger:</b>					
min. riser column Ø	mm	28: H < 20 m 35: H > 20 m	28: H < 30 m 35: H > 30 m	35: H < 20 m 42: H > 20 m	42: H < 30 m 49: H > 30 m
- type of plates	mm	-	CB 30-16 HF	CB 30-30 HF	CB 30-50 HF
- number of plates		-	16	30	50
- plate exchange surface area	m <sup>2</sup>	-	0.41	0.81	1.39
Exchanged power depending on the primary circuit flow rate and primary/secondary circuits temper- ature with 45 % glycol/water: - 30 L/h.m <sup>2</sup> at 60/40 °C	kW/m <sup>2</sup> .°C	-	35	70	108
Primary circuit and/or secondary circuit pressure drop at flow rate 30 L/h.m <sup>2</sup>	mWc	-	1.2	1.4	1.4
<b>Primary circulating pumps:</b>					
- type		MHI 203	MHI 204	MHI 204	MHI 404
- manometric height	mWc	31	42	42	45
- power supply	V	230/single	240/single	240/single	240/single
- current consumption	A	4	3	3	4.8
- power consumption	W	55	55	55	110
Drain tank	L	100	100	150	200
<b>Secondary circulating pumps:</b>					
- type		-	SB 10 YA	SB 50 XA	SB 50 XA
- manometric height	mWc	-	2.5	2.5	2.5
- power supply	V	-	230/single	230/single	230/single
- current consumption	A	-	0.25	0.5	0.5
- power consumption	W	-	56	114	114
<b>Equipment:</b>					
Combine with solar tanks		BLC 400 and 500	FWS 750, 1500	FWS 1500	-
		B 650 to 3000	RSB 650 to 3000	RSB 650 to 3000	RSB 650 to 3000
		B 802 and B 1002	B 650 to 3000	B 650 to 3000	B 650 to 3000
		PS 600 to 3000	PSB 600 to 3000	PSB 600 to 3000	PSB 600 to 3000
Combine with energy meter:					
- solar		-	<b>Included</b>	<b>Included</b>	<b>Included</b>
- system		-	CME + meters	CME + meters	CME + meters

**!** The choice of solar station depends on the primary solar pump output, which must overcome the pressure drops in the collector fields and solar circuit, but also on the volume of the drain tank built into the station, which must be able to absorb the entire volume of the collector fields and solar circuit between collectors and station.

# DRAIN-BACK SYSTEMS IN COLLECTIVE INSTALLATIONS

## HYDRAULIC SCHEMATIC DIAGRAMS OF TRANSFER UNITS

DB 50 S

STSDB 50, 100, 150

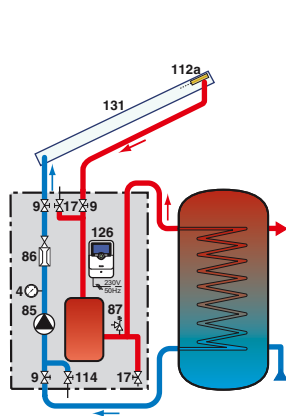

SOL\_F0038

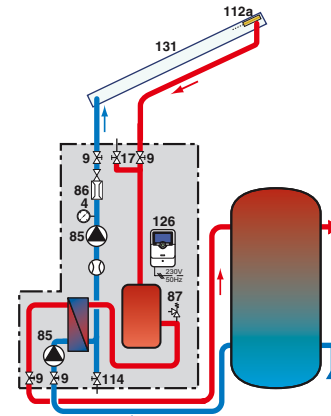

SOL\_F0039

## SOLAR STATION PRESSURE DROPS AND MANOMETRIC HEIGHTS OF SOLAR PUMPS IN RELATION WITH FLOW RATE / SPECIFICATIONS IN PRIMARY/SECONDARY CIRCUITS

### ⇨ Solar primary circuit

DB 50 S

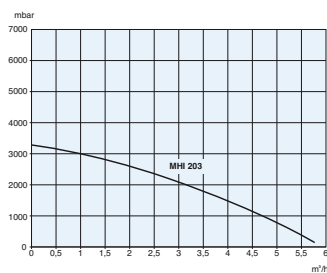

SOL\_F0060

STSDB 50, 100

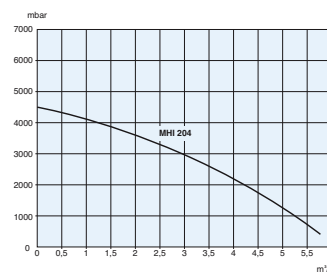

SOL\_F0061

STSDB 150

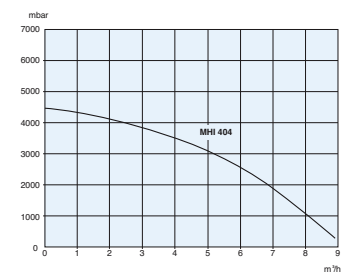

SOL\_F0062

### ⇨ Domestic water circuit

STSDB 50

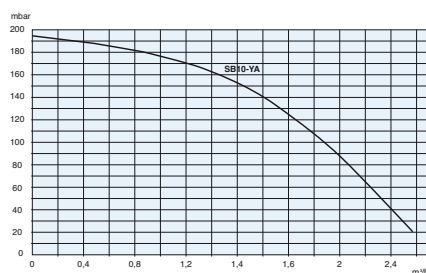

SOL\_F0063

STSDB 100, 150

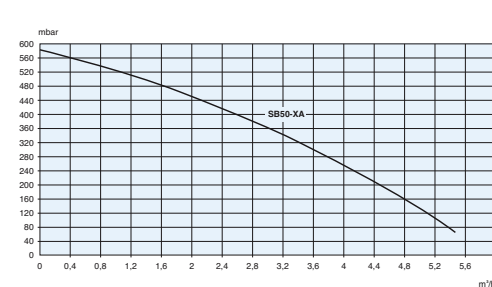

SOL\_F0064

## Dimensions

DB 50 S

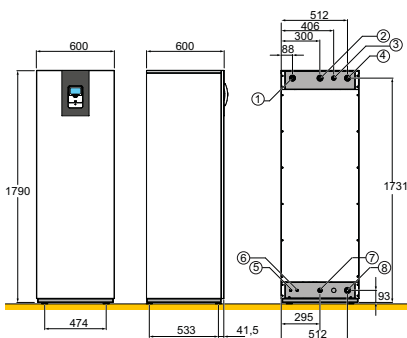

STSDB 50, 100, STSDB 150

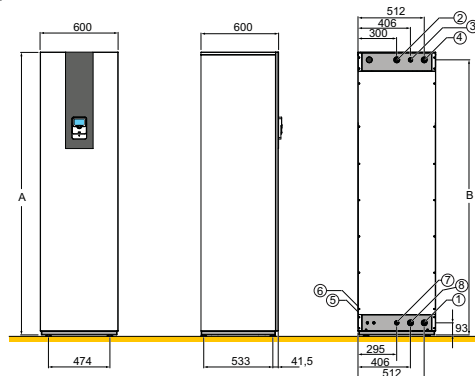

DB\_F0102

### Legend

- ① Solar tank coil inlet G 1
- ② Solar circuit return G 1
- ③ Solar circuit drain G 3/4
- ④ Solar circuit outflow G 1
- ⑤ Power supply cable
- ⑥ Temperature sensor position
- ⑦ Installation filling and draining device G 3/4
- ⑧ Solar tank coil outlet G 1

### Legend

- ① Secondary circuit water outlet G 1
- ② Solar circuit return G 1
- ③ Solar circuit drain G 3/4
- ④ Solar circuit outflow G 1
- ⑤ Power supply cable
- ⑥ Temperature sensor position
- ⑦ Installation filling and draining device G 3/4
- ⑧ Secondary circuit water inlet G 1

	50	100	150
A (mm)	1790	1790	2174
B (mm)	1731	1731	2115

# SOLAR REGULATORS IN COLLECTIVE INSTALLATIONS

## SOLAR REGULATORS

SOL PLUS and SOL SC. 5 are smart, autonomous regulators, which depending on the measured collector and tank temperatures, enable an optimum regulation (matched-flow) concept to be determined for the solar installation concerned. Once the installation has been flushed out and filled, they do not require any further calibration. SOL... regulators are characterised by their simple and clear use: the multi-purpose

display enables simultaneous reading of 2 temperatures; expressive pictograms inform the user particularly simply of the current mode and operating status. It has various connected sensors. Central control is provided via the 3 buttons situated under the display. SOL... regulators come factory-equipped with our solar system regulation program, and an approximate energy meter.

### Regulating principle for pressurised systems

In automatic mode, SOL... regulators operate on the following principles:

- Solar radiation heats the heat-transporting fluid in the collector. To initiate the regulation process, the collector must reach a minimum temperature of 30 °C, and the collector/tank difference must be at least 6 K.
- During the start-up phase, the solar pump is started up at 100 % speed.
- Thereafter, the solar pump fluctuates between 30 and 100 %, and continues loading the tank as long as the temperature difference between the collector and tank remains significant (factory setting 10 K).
- The tank will be continue to be loaded depending on the available heat until it reaches its storage temperature set point (factory setting 60 °C), and then the solar pump will be cut.

- If the sun continues to heat up and the collector reaches its maximum temperature (factory setting 110 °C), the solar pump will be reactivated in order to cool the collectors by 15 K below this value. If the tank temperature exceeds 90 °C, the solar pump will be shut down; the installation is overheated and will protect itself using the steam-back principle. The solar pump will be reactivated at night when the collectors temperature has fallen to cool the tank to the temperature set point.
- The quantity of heat transferred from the collectors to the solar tank under normal operating conditions is counted by the regulator. To obtain an accurate measurement, the installation's various parameters must be recorded on the regulator (see installation manual), or volumetric meters must be connected.

### The various models available

#### SOL PLUS



SOL\_G0001

#### SOL PLUS regulator - Package ER709

Designed for regulating solar installations with optimised loading of tanks equipped with 1 built-in heat exchanger. In addition, it has the "Solar First" solar priority function, preventing the back-up from operating once the solar pump has started. It can also manage a simple solar system with a coil exchanger built into the tank + a three-way valve, 2 collector fields, 2 tanks with built-in exchanger or 1 tank + pool. It is delivered with 3 sensors. SOL PLUS consumption: 1 W.

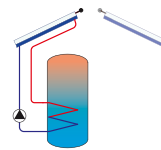

SOL\_F0120

#### SOL SC. 5



SOL\_G0005

#### SOL SC. 5 regulator - Package ER672

Designed for regulating collective solar installations, it provides multiple solutions for regulating the most complex solar installations of up to 4 solar tanks, with solar stations or without plate heat exchanger. It comes built into the STS transfer units, and is delivered pre-programmed with 2 predefined schematics. It can be connected to a computer for remote queries via a communication interface (optional). SOL SC. 5 consumption: 2 W.

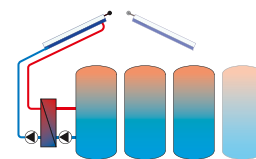

SOL\_F0120

#### SOL CS



SOL\_G0007

#### SOL CS regulator (comes built into DB and STSDB.. solar stations)

A regulator identical to SOL PLUS, with an added primary and secondary energy metering function.

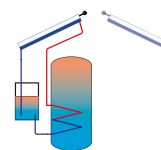

SOL\_F0120

## Options for solar regulators

### DL 2



8980Q272

#### DL 2 communication interface - Package ER55

Connected to the solar regulator, the DL 2 communication interface stores the requested records: collector/tank temp., sunlight (via the CS 10 irradiation sensor - package ER175 - options, see p. 53), energy supplied (thanks to the energy meters supplied on an optional basis - see p. 53), etc. at regular intervals. In addition, it enables:

- retrieval of recorded data via a cable directly onto a PC (software supplied),
- connection via Internet to a remote PC, which in this case enables remote viewing of the installation's operation, malfunctions detection and data retrieval from an assistance centre.

The software supplied with DL 2 provides processing of the extracted data and presentation in the form of an ".xls" file.



8980Q254

#### PT 1000 dip sensor - Package EC173



8980Q255

#### PT 1000 probe sensor - Package EC171



8980Q253

#### Collector sensor - Package EC155



8980Q260

#### Kit of 2 3/4" valves + sensor - Package EC432

For regulating an installation with 2 EAST/WEST collector fields, with SOL SC. 5.



SOL\_Q0003

#### PWM connection kit for a 2<sup>nd</sup> solar pump - Package ER712

Enables a 2<sup>nd</sup> pump to be connected to the SOL PLUS regulator (installations with 2 tanks or 2 EAST/WEST collector fields).

### DL 3



8980Q301

#### DL 3 communication interface - Package ER139

The DL 3 interface has the same functions as DL 2, but is designed for centralising data from 3 installations (i.e. 3 solar regulators combined with 3 CME measurement stations and/or WMZ measurement units). A data downloading software is supplied with the interface. Communicates with the protocols VBus (internal), Backnet (GTB-remote data transmission).



SOL\_Q0002

#### ModBus cable kit (3 m) - Package ER713

For connection between a SOL PLUS regulator and a control panel.



8980Q279

#### Lightning arrester unit for SOL... regulator - Package EC176

To be installed on the solar circuit by the collector.



8980Q240

#### 3/4" three-way valve with reversal motor - Package EC164

For solar circuit with 2 tanks and SOL PLUS regulator



8980Q263

#### DIEMASOL AM1 breakdown report module - Package ER314

Operating error alarm, via flashing indicator lights and reports on the building management systems (relay output). VBus connection to SOL regulators.



8980Q289

#### CS 10 irradiation sensor - Package EC175

For STS stations only. Replaces the collector sensor, which must remain in place on the solar installation.



8980Q281

#### Lightning arrester unit - Package EC176

For SOL regulator. Protects the regulator from overvoltages from the collector field.

## ⇒ Other regulators



8980Q275

#### MCDB regulator - Package EC162

In installations with SOL PLUS, manages energy transfer from one buffer tank to another, and vice versa. It is delivered with 3 sensors.



8980Q107A

### SLA 2

#### SLA 2 differential regulator - Package EC320

It is delivered with 2 sensors, and enables:

- the temperature of an independent tank combined with a boiler (no regulator), a buffer tank with boiler (no regulator), a buffer tank with wood boiler, or a solar buffer tank,

- monitor the heating return and bypass the solar tank if the return temperature is greater than the solar tank temperature.

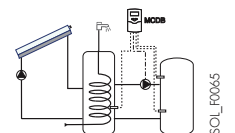

SOL\_F0065

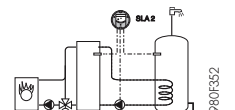

8980F352

## Energy metering

If energy metering or installation monitoring is required, we offer a whole range of components able to provide this (see

current products catalogue, or specific technical booklet).

# SETTING UP THE COLLECTOR PRIMARY CIRCUIT

## COLLECTOR PIPES (PRIMARY CIRCUIT)

The connection pipes between the collector field and the solar tank exchanger or station must be routed as directly as possible, with a constant downward gradient.

The materials used must be compatible with the heat-transporting fluid.

We recommend using copper tubes with brass valves or non-galvanised steel tubes (galvanised tubes and valves, as well as graphite seals are prohibited) or the optional "duo-tube" (synthetic materials are prohibited because of the high temperatures).

- welds must be performed by brazing with a strong filler metal, without a flux (L-Ag2P or L-CuP6),
- union connectors can be used only if they can withstand the heat-transporting fluid at the pressure (6 bar) and temperature (- 30 °C to + 180 °C),
- hemp should be employed only in combination with high temperature and pressure resistant mastic,
- in case of a high point, a manual vent must be installed,
- a safety valve and expansion vessel must be fitted.

## Pipe thermal insulation

All the pipework must be insulated. To limit heat losses, it is advisable to make the pipes as short as possible (< 5 linear m per m<sup>2</sup> collectors installed).

The tube lagging must have the following specifications:

- withstand temperature differences of between -30 and + 180 °C in the collector zone,
- withstand UV and bad weather on the roof,

- be continuous and at least equal in thickness to the pipe, with a min. thermal coefficient  $\lambda$  of 0.04 W/m<sup>2</sup>.°C.
- outside, it must be fitted with an additional protector against mechanical damage, UV rays and birds, comprising an aluminium sheet sleeve sealed with silicone,
- recommended materials: Armaflex, Aeroflex SSH, glass wool.

Below are the thermal coefficient values  $\lambda$  for various insulations:

The table below uses the thickness of a glass wool insulation ( $\lambda = 0.04$  W/m<sup>2</sup>.°C) as a function of pipe diameter:

Insulation	$\lambda$ in W/m <sup>2</sup> .°C
Expanded cork	0.043
glass fibre	0.041
Closed cell insulation, such as Armaflex or similar	0.035
Rigid polyurethane foam (NFT 56-203)	0.024

Insulation thickness (mm)	Pipe diameter (mm)
30	<60
40	from 60 to 110
50	from 110 to 250

## PIPES (SECONDARY CIRCUIT)

We recommend using copper tubes with brass valves or non-galvanised steel tubes (galvanised tubes and valves, as well as graphite seals are prohibited) or the optional "duo-

tube" (synthetic materials are prohibited because of the high temperatures). Pipe insulation must meet the same criteria as those stated in the previous paragraph.

## MANIFOLD CIRCUIT SIZING (PRESSURISED CIRCUIT)

To minimise pressure drops in the solar circuit, the circulation speed in the pipes must not exceed 1 m/s. We recommend speeds of around 0.3 to 0.5 m/s, which limits pressure drops to approximately 3 mbar/linear m of pipe. For an installation of up to 20 m<sup>2</sup>, you can adopt a max. flow rate of 50 L/h and m<sup>2</sup> of collectors; above a solar surface area of 20 m<sup>2</sup>, 40 L/h.m<sup>2</sup>. In many cases, in order to reduce pump output or

even pipe cross-sections, the installation has to operate at flow rates around 15 L/h.m<sup>2</sup> lower, hence it rapidly reaches high temperatures. Below is a table indicating for various collector surface areas, a flow rate of 15, 30 or 50 L/h m<sup>2</sup> and a circulation speed of 0.5 and 1 m/s (pressure drop between 1 and 2.5 mbar/m), the min. tube diameters to use.

## Pipe min. diameter/pressure drop

Solar collectors inlet surface area (m <sup>2</sup> )	Number of collectors		Flow rate 15 L/h.m <sup>2</sup>				Flow rate 30 L/h.m <sup>2</sup>				Flow rate 50 L/h.m <sup>2</sup>						
			Fluid speed		Fluid speed		Fluid speed		Fluid speed								
			< 0.5 m/s	< 1 m/s	< 0.5 m/s	< 1 m/s	< 0.5 m/s	< 1 m/s	< 0.5 m/s	< 1 m/s							
CH 250	POWER 15	Flow rate (L/h)	Tube Ø (mm)	Pressure drop/m (mWc)	Tube Ø (mm)	Pressure drop/m (mWc)	Flow rate (L/h)	Tube Ø (mm)	Pressure drop/m (mWc)	Tube Ø (mm)	Pressure drop/m (mWc)	Flow rate (L/h)	Tube Ø (mm)	Pressure drop/m (mWc)	Tube Ø (mm)	Pressure drop/m (mWc)	
10	4	6	150	15	0.1	14	0.1	300	18	0.2	18	0.2	500	22	0.1	18	0.4
15	6	8	225	15	0.4	14	0.4	450	22	0.1	18	0.4	750	28	0.1	22	0.3
20	8	12	300	18	0.2	18	0.2	600	22	0.2	22	0.2	1000	28	0.2	22	0.4
30	12	18	450	22	0.1	18	0.4	900	28	0.1	22	0.4	1500	35	0.1	28	0.3
40	16	23	600	22	0.2	22	0.2	1200	28	0.2	28	0.2	2000	42	0.2	35	0.2
60	26	35	900	28	0.1	22	0.4	1800	35	0.1	28	0.4	3000	42	0.2	35	0.3
80	34	-	1200	28	0.2	28	0.2	2400	42	0.1	35	0.2	4000	52	0.1	42	0.2
100	42	-	1500	35	0.1	28	0.3	3000	42	0.3	35	0.3	5000	68	0.1	42	0.4

## Maximum connection length (F + R) in metres, depending on the station

Solar collectors inlet surface area (m <sup>2</sup> )	Number of collector fields	Collector field press. drop (up to 8 in series), flow rate		Column min. Ø		DKSC 6 MSB		SKS 13-45		STS 14-30		STS 14-50		STS 14-100	
		15 L/h.m <sup>2</sup> (mWc)	30 L/h.m <sup>2</sup> (mWc)	15 L/h.m <sup>2</sup> (mWc)	30 L/h.m <sup>2</sup> (mWc)	15 L/h.m <sup>2</sup> (mWc)	30 L/h.m <sup>2</sup> (mWc)	15 L/h.m <sup>2</sup> (mWc)	30 L/h.m <sup>2</sup> (mWc)	15 L/h.m <sup>2</sup> (mWc)	30 L/h.m <sup>2</sup> (mWc)	15 L/h.m <sup>2</sup> (mWc)	30 L/h.m <sup>2</sup> (mWc)	15 L/h.m <sup>2</sup> (mWc)	30 L/h.m <sup>2</sup> (mWc)
10	1	0.4	1	15	18	44	-	53	36	-	-	-	-	-	-
15	1	0.5	1.3	18	18	43	-	52	34	-	-	-	-	-	-
20	2	0.4	1	18	22	44	-	53	36	59	51	-	-	-	-
30	2	0.5	1.3	22	28	-	-	52	34	59	50	56	39	-	-
40	3	0.4	1.2	22	28	-	-	53	35	-	-	57	40	-	-
60	4	0.5	1.3	28	36	-	-	-	-	-	-	56	39	55	38
80	5	0.5	1.3	28	42	-	-	-	-	-	-	-	-	55	38
100	6	0.5	1.3	35	42	-	-	-	-	-	-	-	-	55	38

## VENT

Each high point of a bank and of a circuit must be equipped with a manual or automatic vent combined with an isolating

valve able to withstand glycol water and temperatures above 120 °C.

## CIRCULATING PUMP

The circulating pump, by circulating the heat-transporting fluid, transfers the energy accumulated by the collectors to the solar exchanger. The pump should be sized to:

- overcome circuit pressure drops below the maximum authorised circulation speed (via the positioning of the hydraulic circuit),

- ensure a minimum heat-transporting fluid flow rate. The fluid flow rate must be between 15 and 50 l/h per m<sup>2</sup> of collectors, and its speed must be less than or equal to 1 m/s.

## Pressure drops

Circuit pressure drops are caused by:

- pressure drops from collectors and collector banks (see pages 10 and 12),
- pressure drops from the pipework,
- pressure drops from the solar exchangers (see the tables of specifications of the various tanks in the current pricing catalogue).

If the collector banks are connected in series, the various pressure drops are added together. Parallel connection reduces pressure drops.

## Flow rate in the manifold circuit (primary circuit)

The sizing of the pipes and the pump is connected. It is about ensuring the design flow rate in the collectors. In particular, the total circuit pressure drop (including collectors) must be less than the pressure drop authorised for the pump at the design flow rate.

You can adjust the pipework diameter, and also possibly the pump output.

The pipe diameters in the table on the previous page is for information only, and non-binding. If the choice involves other diameters, the pump manometric height will be directly affected. For surface areas < 50 m<sup>2</sup>, the choice of manifold pump diameter results from the manometric height of the selected pump (often 6, 9, 11 mWc), minus the pressure drops from the solar field, solar station and hydraulic circuit regulating components.

Hence in nearly all installations < 30 m<sup>2</sup> (low flow), we recommend a min. diameter of 22 mm, and for installations < 50 m<sup>2</sup>, a min. diameter of 28 mm. For the installation to work properly, a flow rate adjustment valve must be set up for each bank.

## SAFETY VALVE

This valve is obligatory. Its function is to remove any overpressure from the primary circuit. It is built into all of our solar stations.

# SETTING UP THE COLLECTOR PRIMARY CIRCUIT

## EXPANSION VESSEL

A specific expansion vessel for solar installations (glycol-resistant membrane) must be installed, see current regulations. In particular, it must be designed to withstand temperatures of around 120 °C, satisfy an operating pressure of 6 bar, and be able to receive the heat-transporting fluid volume in the collectors.

### Total heat-transporting fluid volume

To determine the total heat-transporting fluid volume, you need to add:

- the collector field volume (number of collectors x unit capacity),
- the exchangers volume (built-in or plate),
- the safety volume in the expansion vessel (0.015 x volume in the installation, or at least 3 litres),
- the volume in the pumps (if unknown, assume as 0.5 m of pipe),
- the pipes volume (see table opposite).

### Sizing

It is difficult to indicate a correct calculation formula for installations with a collectors surface area of more than 20 m<sup>2</sup>, because of their operation on buffer volumes. Nonetheless, below we set out the method for determining the expansion vessel volume. (Note that De Dietrich also offers in its "DIEMATOOLS" software assistance in calculating the expansion vessel dimensions).

The method comprises 6 steps:

#### 1. Determining the inflation pressure P (vessel preloading) in bar

$$P = hst / 10 + Pva + 0.5$$

hst: static height between the vent and expansion vessel (m)

Pva: vaporisation pressure from which the heat-transporting fluid changes to vapour phase

Glycol rate	Water only	20 %	30 %	40 %	45 %	50 %
Vaporisation pressure (bar)	1.70	1.46	1.38	1.31	1.40	1.23

#### 2. Determining the expanded volume Vd in litres

$$Vd = (\text{installation volume (L)} + 3)$$

x expansion coefficient of the water/antifreeze agent mix (‰)

The expansion coefficient is determined from the table below, for the antifreeze agent concentration used (water only 20, 30, 40, 45 or 50 %) at the fluid's mean maximum temperature in the installation:

Glycol rate	Water only	20 %	30 %	40 %	45 %	50 %
Expansion coefficient (m <sup>3</sup> /L)	58.90	59.90	65.29	71.13	77.10	73.92

#### 3. Determining the vapour volume Vv in litres

$$Vv = \text{collectors volume (L)} \times 1.10$$

Collector type	CH 250	CH 250 SL	POWER 15
Volume per collector (L)	1.7	1.2	2.0

The various expansion vessels that we offer:

50 L: Package EG83

80 L: Package EG84

100 L: Package EG120

200 L: Package EG122

300 L: Package EG123



8960Q043

### Volume per linear metre of pipe

Ext. Cu tube Ø	18x1.0	22x1.0	28x1.5	35x1.5	40x1.5	50x1.5	54x1.5
l/m	0.20	0.31	0.49	0.84	1.11	1.66	2.04
Steel tube	1/2"	3/4"	1"	1" 1/4	1" 1/2	2"	2" 1/2
l/m	0.21	0.38	0.61	1.05	1.42	2.73	3.80

### Estimated volume in the steel pipes of given length (litres +/- 10 %)

20 m	4	8	13	21	29	55	76
30 m	6	12	19	32	43	82	114
40 m	8	16	25	42	57	110	152
50 m	10	19	31	53	71	137	190

The expansion vessel sizing involves determining:

- its inflation pressure (preloading)
- its capacity (volume)

The data to have to hand are:

- the installation's heat-transporting fluid capacity (l),
- the heat-transporting fluid capacity in the collectors (l),
- the static height of the installation (m),
- the rated pressure of the safety valve (bar),
- the percentage glycol in the heat-transporting fluid (%).

#### 4. Total expansion volume Vet in litres

$$Vet = 3 + Vd (l) + Vv (l)$$

#### 5. Expansion vessel efficiency η

$$\eta = (\text{final pressure} + 1) - (P + 1) / (\text{final pressure} + 1)$$

where final pressure (bar) = Valve max. pressure - 0.50

#### 6. Expansion vessel (minimum) volume Vm in litres

$$Vm = Vet / \eta$$

### Example of determination

Data:

- 10 Pro C collectors
- installation volume: 48 L
- collectors volume: 23 L
- static height: 15 m
- valve pressure rating: 6 bar
- percentage glycol: 40 %

Vessel sizing:

- Preload = 15/10 + 1.31 + 0.5 = 3.31 bar
- Expanded volume = (48 + 3) x 71.13/1000 = 3.6 L
- Vapour volume = 23 x 1.10 = 25.90 L
- Total expansion volume = 3 + 3.6 + 25.90 = 32.5 L
- Efficiency = ((6 - 0.5) + 1) - (3.31 + 1) / ((6 - 0.5) + 1) = 0.3369
- Minimum vessel volume = 32.5 / 0.3369 = 96.5 L

## HEAT-TRANSPORTING FLUID

### Choice of fluid

A solar system operates with a heat-transporting fluid which transfers the energy captured by the solar collector to the hot water tank. As for all open-air circuits, the solar circuit needs to be provided with protection against frost, but also against corrosion. Hence, we advise against using pure water, not only for these 2 reasons, but also because water vaporises at 100 °C, while a suitable fluid vaporises at around 130 °C or 150 °C, depending on the pressure; so the installation will be overheated much later with a fluid than with water. So for all collective solar installations, we recommend our heat-transporting fluids, which are suitable both for winter temperatures and summer overheating.

There are two types of fluid available:

- **LSpremix:** package EG 100 (20 litres).

This is a mix comprising 43 % propylene glycol and 57 % water with protection from - 28 °C to + 160 °C

- **BIOpremix:** package ER316 (20 litres).

This is a natural green-coloured maize-derived product, which is biodegradable and has a 40% smaller ecological and energy footprint than glycol. With this product corrosion is better controlled (contains less acid). It is an AFSA-approved product, a very good antifreeze agent (down to - 26 °C) and highly resistant to high temperatures (up to 250 °C) and ageing.

- All our fluids can be used in Drain-Back installations, for which we recommend a mix with at least 15 % antifreeze agent.

### Fluid vapour pressure in the collector

#### Remarks:

- For the regulators to operate correctly within the safety ranges (up to 130 °C), the pressure in the installation must be calculated so that the fluid vaporisation point is greater than 130 °C (at least 2 bar in the collectors).

Opposite are the percentage expansion and vaporisation pressure as a function of temperature for the fluids that we offer.

**⚠ Note also when calculating this pressure the height of the building on which the solar collector field is installed.**

De Dietrich also in its offers "DIEMATOOLS" software expansion vessel sizing assistance and recommendations.

### Percentage expansion as a function of temperature

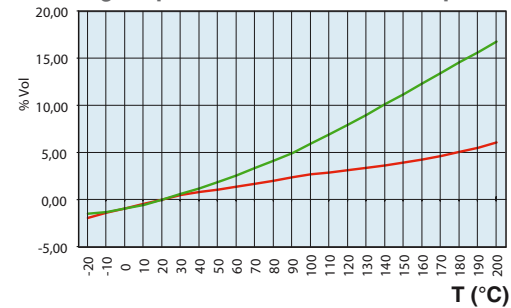

### Absolute vapour pressure

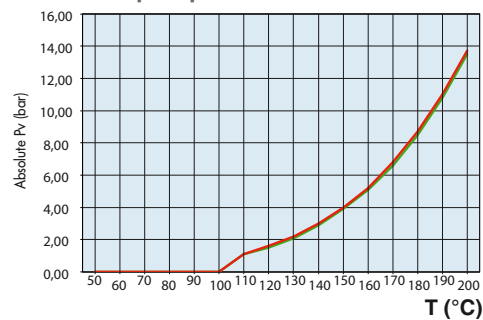

— LSpremix      — BIOpremix

PROC\_F0035

PROC\_F0035

### Ageing resistance of fluids

Acid proportion at 150°C (ppm)

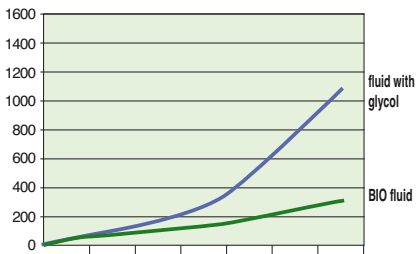

PROC\_F0024

## DUO-FLEX

EG423/424



SOL\_G0004

**Duo-Flex kit Ø 20 x 15 m** - Package EG423

**Duo-Flex kit Ø 20 x 20 m** - Package EG424

**Duo-Flex kit Ø 25 x 25 m** - Package EG426

Non-insulated stainless steel flexible double tubes with sensor cable (and Easydic connectors included)

for packages EG423 and EG 424) for rapid connection of the collector field to the solar station.

**Set of 2 Easydic 1" 1/4 connectors for Ø 25 mm Duo-Flex** - Package EG427

For connecting to the solar station or between 2 Duo-Flex double tubes (accessibility to the connectors is obligatory).

# -sizing a collective solar installation for DHW production

A collective installation for hot water production must be sized by an engineering design firm competent in the field.

Below you will find the information need to enable you to conduct a pre-study of this sort of installation, and subsequently cost the main components of the potential installation.

## Calculating DHW Daily Requirements (As per GRDF Boiler Room Guide)

### Important

To size a solar installation, **it is important not to overestimate DHW requirements**. It is always recommended to underestimate consumption if it is not known, rather than overestimate

it, to prevent overheating problems, and above all to increase performance and therefore generate more savings.

### Collecting DHW requirements data

- The domestic hot water temperature set point is assumed to be constant year round.

- The volume  $V_i$ , the average daily domestic hot water consumption, should be estimated using the tables below, or measured using a flowmeter (meter) fitted in the installation, if not known.

Below are the domestic hot water requirements in different sectors of the collective field:

### Collective housing

	DHW requirements in l/day at 60 °C
T1/T2 with shower	72
T1/T2 with bath	108
T3/T4 with bath	120
T3/T4 with shower + bath	156
T5/T6 with bath	144
T5/T6 with shower + bath	156
T5/T6 with 2 x baths	180

### Tertiary sector

#### - Hotel sector

The daily DHW requirement is dependent on the number of stars, rooms and daily meals:

	DHW requirements in l/day at 60 °C					
Hotel class	0 *	*	**	***	****	*****
Rooms	60	70	100	120	150	180
Meals	8	8	12	15	20	20
Breakfast	4	4	4	4	4	4

#### - Retirement home/Care home

The daily DHW requirement is dependent on the number of beds and daily meals (residents + personnel):

	DHW requirements in l/day at 60 °C
Beds	40
Meals	10

#### - Boarding school

The daily DHW requirement is dependent on the number of rooms:

	DHW requirements in l/day at 60 °C
Rooms	60

#### - Student residence and workers hostel

The daily DHW requirement can be estimated by referring to the "collective housing" paragraph, assuming that each room is a studio (T1).

#### - Hospital/clinic

The daily DHW requirement is dependent on the number of beds and daily meals (patients + personnel):

	DHW requirements in l/day at 60 °C
Beds	70
Meals	12

#### - Catering

The daily DHW requirement is dependent on the type of establishment and the number of meals:

	DHW requirements in l/day at 60 °C			
Type of establishment	Standard	Luxury	Fast food	Canteen
Meals	12	20	6	5

#### - Camping/open-air tourism

The daily DHW requirement is dependent on the campsite's number of stars, and if the campsite is on the coast, 25% should be added to the values given below:

	DHW requirements in l/day at 60 °C		
Campsite class	**	***	****
Location	40	50	60

#### - Sports facility and pool

The daily DHW requirement is dependent on the number of daily showers and type of shower:

	DHW requirements in l/day at 60 °C
Standard shower	30
Push-button shower	20

**- Factory**

The daily DHW requirement is dependent on the number of occupants:

DHW requirements in l/day at 60 °C	
Occupants	25

**- Offices**

Collective DHW production is unsuitable for offices, given the low requirements and distribution losses. DHW requirements at 60 °C are estimated at 5 l/day per person present:

	Individual single-tap basin	Shower without changing room or communal shower	Shower with changing room or cubicle shower
DHW volume at 60 °C	15	20	30
Duration in mins	3 to 5	5 to 6	10 to 15

**DEFINITION OF THE MAIN COMPONENTS**

**Flat and tubular collector surface area**

The collector surface area governs the system's cost and performance. In the pre-sizing approach, the surface area required  $S_0$  is determined as follows:

$$S_0 = V_j / X$$

$S_0$ : inlet surface area flat collector (m<sup>2</sup>)

$V_j$ : average daily domestic hot water consumption (L)

$X$ : volume of water (l) heated per m<sup>2</sup> of collectors. This parameter is dependent on the climate zone, and may vary between 70 and 110.

**Note:**

- for tubular collectors, the inlet surface area must be reduced by approximately 25 % compared to flat collectors,
- for a Drain-Back system, the collectors surface area may be increased by ± 10 %, if this is economically acceptable.

**Volume of water heated to 60 °C per m<sup>2</sup> of collectors by climate zone**

Zone 1	70 L/d for 1 m <sup>2</sup>
Zone 2	80 L/d for 1 m <sup>2</sup>
Zone 3	95 L/d for 1 m <sup>2</sup>
Zone 4 (French Overseas Depts & Territories, Canary Islands)	110 L/d for 1 m <sup>2</sup>

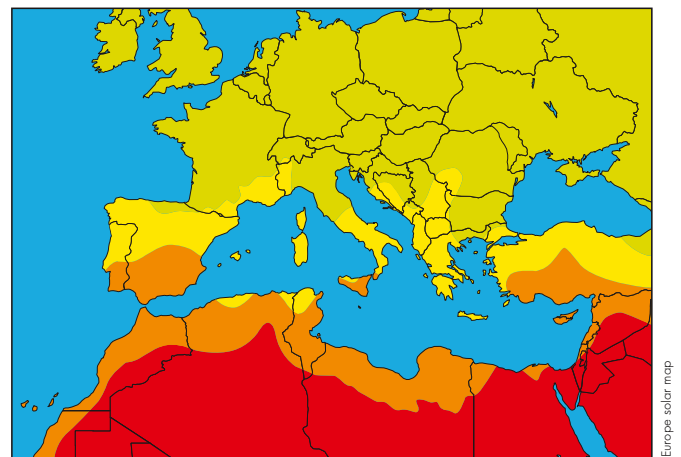

**Constraints**

With the collectors surface area  $S_0$  determined in this way, you can check:

- whether the cost of the collectors corresponds to the planned investment,

- whether the planned location actually enables it to be installed (see page 14). The choice of collectors angle is dependent on the requirement, if this is seasonal: 30° for high requirements in summer, 60° for high requirements in winter, 45° for year-round use.

**The following correction factors should be applied if the optimal angle cannot be maintained**

Hence either constraint may vary the initially pre-sized collectors surface area. The annual quantities of solar energy received in kWh/m<sup>2</sup>.day indicated on the geographic map on page 3 correspond to optimum collector orientation: facing south, angle 45°.

If the collectors field positioning is different from these data, the average daily sunlight will be reduced as per the following correction coefficients:

**Correction factor  $f_i$**

This diagram sets out the correction factor  $f_i$  to apply, as a function of the collectors angle in relation to the optimum angle. Example: for a roof with a 25° slope, the correction factor will be 0.95.

The efficiency of the solar installation will be reduced by 5 % from an ideal installation.

NB: no installing a collector with an angle < 25°, unless the installation is only for summer use.

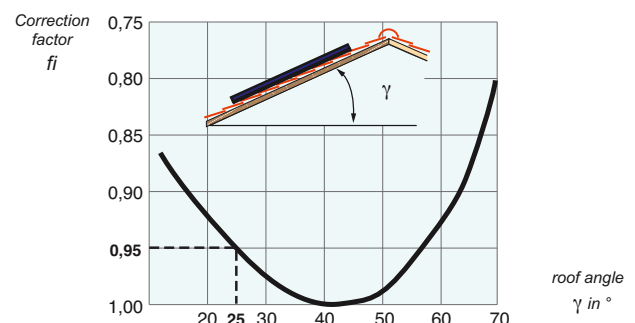

8980FC008

# -sizing a collective solar installation for DHW production

## ⇒ Correction factor fo

This diagram sets out the correction factor fo to apply, as a function of the solar collectors orientation in relation to south  
**Example:** for a collectors installation oriented 50° south-east, the correction factor is 0.83.

The efficiency reduction due to the differences from the ideal orientation or angle can be offset to restore the initial value X by adding additional collectors.

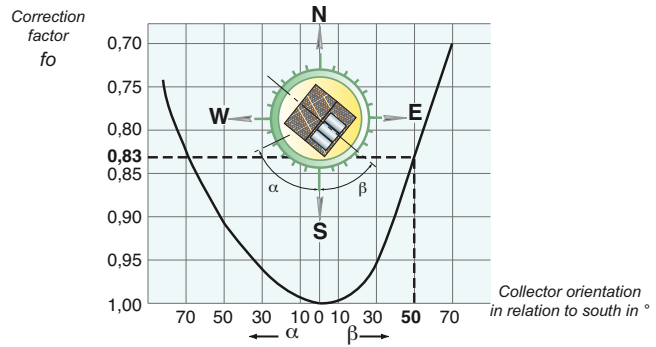

## THE SOLAR STORAGE VOLUME (PRESSURISED SYSTEM)

The storage volume is determined as a function of the maximum daily volume of domestic hot water consumed over the period May-August (Metropolitan France) and the size of the room accommodating it.  
 Storage can be provided by several tanks, which will be connected in series. If space for the storage volume is limited, you must reduce the solar collectors surface area, or switch to the Drain-Back system.

Minimum value to respect:  
**50 litres storage per m<sup>2</sup> of collectors**

$$V_{sto} = V_{moy} + 20\%$$

Where  $V_{sto}$ : storage volume (L)  
 $V_{moy}$ : maximum daily volume of domestic hot water consumed (L/day)

## Sizing solar exchangers

To operate a solar installation in both summer and winter, it is vital to use antifreeze agent as the heat-transporting fluid. This fluid ensures operation of the collectors from

-30 to 130 °C, and protects them against frost and vapour formation. So the presence of an exchanger on the installation is essential.

There are two distinct types of exchanger:

### ⇒ Exchanger built into the storage system (coil exchanger)

To connect a solar field to a solar tank with built-in exchanger, it is important to check the following surface areas ratio:  
 - Smooth tube exchanger: 0.2 to 0.3 m<sup>2</sup> of tube per m<sup>2</sup> of collectors installed  
 - Finned tube exchanger: 0.3 to 0.4 m<sup>2</sup> of tube per m<sup>2</sup> of collectors installed  
 The exchange coefficient must be around 100 W/m<sup>2</sup>.°C

### ⇒ Exchanger outside the storage system (plate heat exchanger)

To connect a solar field to a plate heat exchanger, it is important to check the following surface areas ratio:  
 - 0.15 to 0.3 m<sup>2</sup> of exchange surface area per m<sup>2</sup> of collectors installed.  
 For exchange between the primary circuit (solar) and the secondary circuit (application), it is important to have a temperature difference of 5 K to limit the efficiency losses. The exchanger power must be 100 W/°C per m<sup>2</sup> of collectors at flow rate (15 L/h.m<sup>2</sup>).  
 The peak pressure drop caused by the exchanger must not exceed 100 mbar.  
 Power losses are in these cases around 5 % (35 W per m<sup>2</sup> of collectors) of the built-in exchanger.

There are 2 methods of calculating the useful power of a solar collector:

#### Method ①, as per standard NFP 50-501

Useful power in W/m<sup>2</sup> at the exchanger inlet:  
 $P = (B \times I) - K \times (\Delta T)$   
 Where  $B$  = collector optical factor (unitless)  
 $K$  = overall thermal transmission coefficient K of the collector in W/m<sup>2</sup>.K  
 $I$  = power received by the collector in W/m<sup>2</sup>  
 (≈ 1000 W/m<sup>2</sup> sunny with no clouds)  
 $\Delta T$  = difference between temperature of liquid in the collector (≈ 65 °C) and the external temperature (25 °C in summer)

#### Method ②, as per EN 12975

Useful power in W/m<sup>2</sup> at the exchanger inlet:  
 $P = I \times \eta_0 - (a_1 \Delta T + a_2 \Delta T^2)$   
 Where  $I$  = power received by the collector in W/m<sup>2</sup>  
 (≈ 1000 W/m<sup>2</sup> sunny with no clouds)  
 $a_1$  and  $a_2$  = collector transmission losses coefficient in W/m<sup>2</sup>.K for  $a_1$  and W/m<sup>2</sup>.K<sup>2</sup> for  $a_2$   
 $\eta_0$  = collector optical efficiency  
 $\Delta T$  = difference between temperature of liquid in the collector (≈ 65 °C) and the external temperature (25 °C in summer)

# INFORMATION ON PREVENTING SCALDING BY DHW AND LEGIONELLA DEVELOPMENT

## FRENCH REGULATIONS - COMPLY WITH LOCAL REGULATIONS

The tanks must be installed and operated in accordance with the national regulations in force.  
To limit the development of bacteria, the temperature of the hot water distributed must be at least 60 °C out of the storages, and of the installation contains a recirculation loop, the water temperature at the return must be at least 50 °C. Users must in every case be protected against risks of scalding at draw-off points, where the drawn water temperature must not exceed 50 °C.

A new draft modification of article 36 of the Order of 23 June 1978 is in progress.

This draft specifies the terms of application of this modified article 36 of the Order of 23 June 1978, which must prevent risks relating to legionella and scalding in fixed installations aimed at supplying domestic hot water to homes, offices or establishments open to the general public.

### REQUIREMENTS RELATING TO SCALDING

Accidental scalding by domestic hot water occurs frequently, with serious consequences, especially because of its wide impact. Approximately 15 % of scalds are reportedly caused by an excessively high domestic hot water temperature, with the bathroom as the origin. We suggest replacing article 36 of the Order of 23 June 1978 with the following paragraphs:

“domestic hot water distribution installations”

1 . In order to limit the risk of being scalded:

- in bathrooms, the maximum temperature of the domestic hot water is set at 50 °C at the draw-off points;
- in other rooms, the maximum temperature of the domestic hot water is limited to 60 °C at the draw-off points;
- in kitchens and laundry rooms of establishments open to the general public, the temperature of the water distributed may be increased up to 90 °C at certain points subject to special signage.

#### Example 1

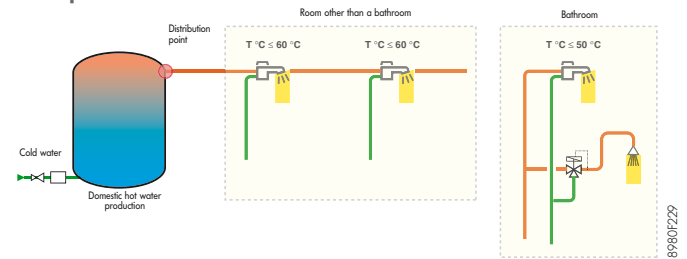

#### Legend

- Draw-off point **AT NO PARTICULAR RISK** from legionella
- Draw-off point **AT RISK** from legionella
- Area subject to requirements in the example

Source: taken from a DGS draft circular

### REQUIREMENTS RELATING TO LEGIONELLA IN STORAGE DEVICES AND IN DISTRIBUTION NETWORKS

Legionnaire's disease is caused by inhalation of a water spray contaminated by legionella. Water temperature is an important factor in preventing the development of legionella in the distribution networks, since the Legionella bacterium has a high growth capacity in water with a temperature of between 25 and 43 °C.

We suggest replacing article 36 of the Order of 23 June 1978 with the following paragraphs:

“domestic hot water distribution installations”

2. The at-risk draw-off points defined in the present paragraph are points prone to cause exposure of one or more people to water spray; this involves showers in particular.

In order to limit the risk of legionella development in domestic hot water distribution systems to which at-risk draw-off points might be connected, the following requirements must be respected when using domestic hot

water production and distribution systems, and in the 24 hours preceding their use:

- if the volume between the distribution point and the furthest draw-off point is more than 3 litres, the water temperature must be 50 °C or more at any point of the distribution system, with the exception of the final supply tubes. The volume of these final supply tubes is as low as possible, and in every case 3 litres or less;
- if the total volume of the storage equipment is 400 litres or more, the water contained in the storage equipment, excluding the preheating tanks, must be:
  - constantly at a temperature of 55 °C or more at the equipment outlet;
  - or be raised to a sufficient temperature at least once every 24 hours. Appendix 1 states the minimum water temperature holding time temperature to respect.

#### Appendix 1 : minimum daily water temperature increase time in the storage equipment, excluding the preheating tanks

Minimum temperature maintenance time (mins)	Water temperature (°C)
2	70 or above
4	65
60	60

#### Example 2: storage tanks present in distribution

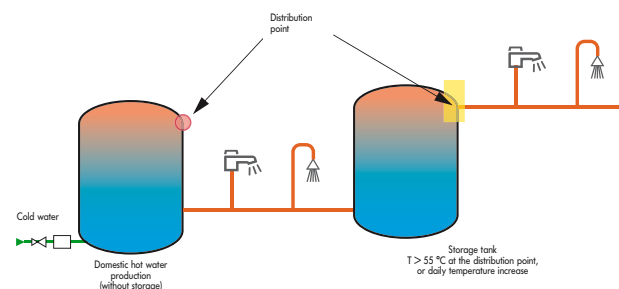

# LEGEND FOR INSTALLATION DIAGRAMS

<b>1</b>	Heating flow	<b>29</b>	Pressure reducer (if supply pressure > 80% of the safety valve rating)	<b>87</b>	Safety valve calibrated to 6 bar
<b>2</b>	Heating return	<b>30</b>	Domestic safety unit calibrated and sealed to 7 bar	<b>88</b>	Solar circuit expansion vessel
<b>3</b>	3-bar safety valve	<b>32</b>	DHW loop pump	<b>89</b>	Container for solar fluid
<b>4</b>	Pressure gauge	<b>33</b>	DHW sensor	<b>90</b>	Anti-thermosiphon loop (= 10 x tube Ø)
<b>5a</b>	Flow meter	<b>34</b>	Primary pump	<b>101</b>	Ball valve with non-return valve
<b>7</b>	Automatic air vent	<b>35</b>	Low-loss header	<b>109</b>	Thermostatic mixing valve
<b>8</b>	Manual bleed valve	<b>37</b>	Balancing valve	<b>112a</b>	Solar collector sensor
<b>9</b>	Isolation valve	<b>44</b>	65°C safety thermostat with manual reset for underfloor heating	<b>112b</b>	Solar tank DHW sensor
<b>10</b>	Three-way mixer valve	<b>46</b>	2-position three-way directional valve	<b>112c</b>	2 <sup>nd</sup> exchanger sensor
<b>11</b>	Heating accelerator	<b>50</b>	Disconnecter	<b>112d</b>	Plate heat exchanger outflow sensor
<b>13</b>	Flush valve	<b>51</b>	Thermostatic valve	<b>112e</b>	Top DHW sensor
<b>15</b>	Shunt pump	<b>56</b>	DHW circulation loop return	<b>114</b>	Primary solar circuit filling and draining device
<b>16</b>	Expansion vessel	<b>57</b>	Domestic hot water outlet	<b>115</b>	Thermostatic distribution valve for each zone
<b>17</b>	Drain valve	<b>61</b>	Thermometer	<b>124</b>	Thermostat controlled distribution valve
<b>18</b>	Heating circuit filling	<b>64</b>	"Radiator" circuit	<b>126</b>	Solar regulator
<b>20</b>	Water meter	<b>65</b>	Heating circuit with mixing valve (underfloor heating for example)	<b>129</b>	DUO-TUBES
<b>21</b>	Outside sensor	<b>68</b>	Condensates neutralisation system	<b>130</b>	Manual venting degasser (Airstop)
<b>22</b>	Boiler sensor	<b>75</b>	Pump for DHW use	<b>131</b>	Collector field
<b>23</b>	Flow sensor after mixing valve	<b>79</b>	Solar exchanger primary outlet	<b>132</b>	Solar station
<b>24</b>	Exchanger primary inlet	<b>80</b>	Solar exchanger primary inlet	<b>133</b>	Interactive remote control
<b>25</b>	Exchanger primary outlet	<b>85</b>	Primary solar circuit pump	<b>166</b>	Buffer tank pump
<b>26</b>	Booster pump	<b>86</b>	Solar primary flow rate adjustment		
<b>27</b>	Non-return valve				
<b>28</b>	Domestic cold water inlet				

DE DIETRICH THERMIQUE

S.A.S. with corporate capital of 22 487 610 €

57, rue de la Gare - F-67580 MERTZWILLER

Tel. +33 3 88 80 27 00 - Fax +33 3 88 80 27 99

[www.dedietrich-heating.com](http://www.dedietrich-heating.com)