

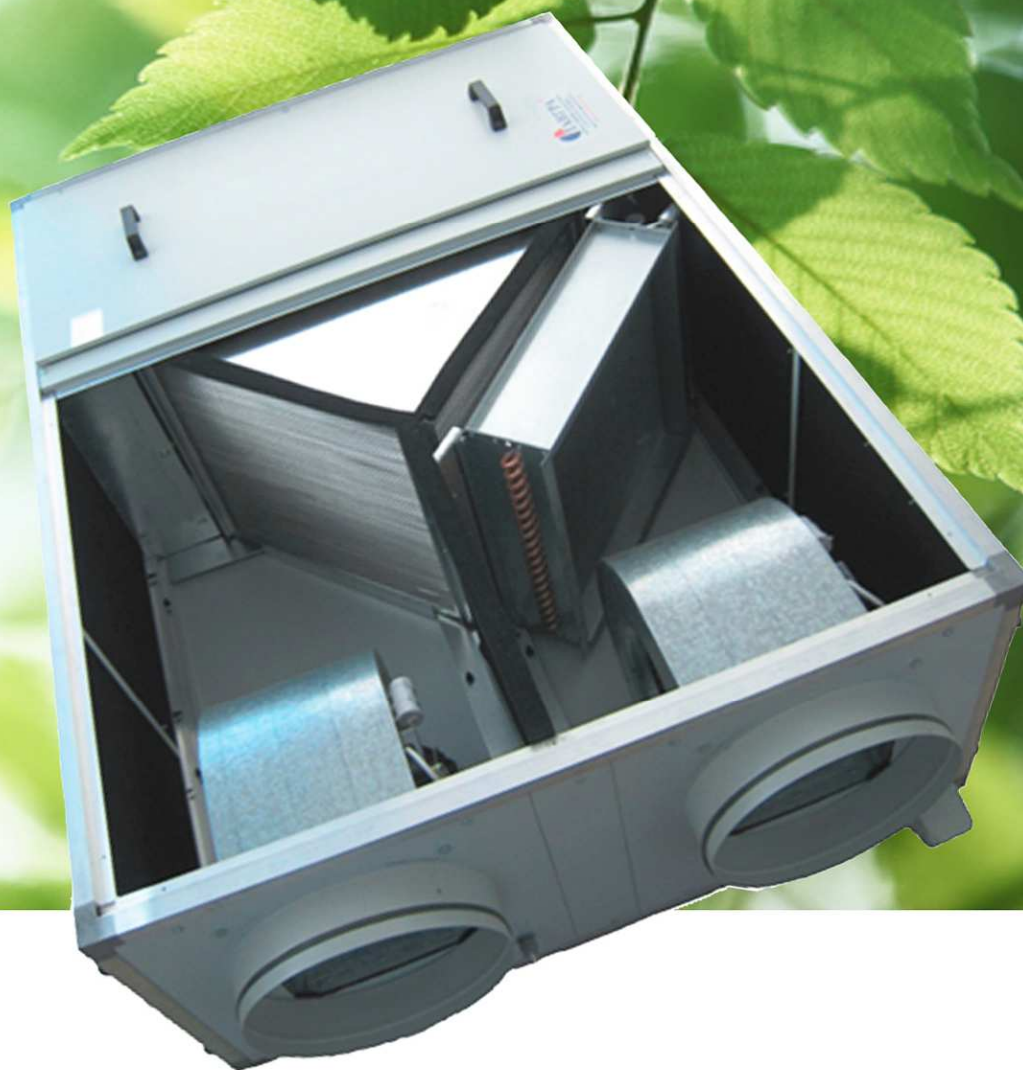

TANGRA®



**HEAT RECOVERY
VENTILATION
EVB - AL/AL+**



Description

Maintaining the microclimat in premises with minimum energy consumption is a major factor in the management of operation costs in buildings. Heat recovery installations provide a flow of fresh air with temperature, close to this in the room using the heat of the exhausted air.

The heat recovery units manufactured by TANGRA are designed for installation in:

- Apartments and family houses
- Offices
- Trade centers
- Hotels and restaurants
- Factories
- Agricultural facilities

Bypass

Under certain temperature conditions, a device controls the ON/OFF function of the automatic bypass. In this way, the fresh air passes through the filter and is directly supplied to the room without going through the heat exchanger. This mode is called "free-cooling". As a standard the ambient temperature is set between $16 \div 24^{\circ}\text{C}$.

Construction and insulation

Construction of anodized aluminium profiles.
Side panels produced in two versions:

- Single panel with inner insulation (13mm)
- Double panels "sandwich" type with 25mm insulation.

There is a possibility to change the directions of fresh and exhausted air by changing the place of the side panels (see p.15).
Drain connection is located at the bottom side.

Air filter

As a standard the unit is delivered with filter G4 EN 779:2002 for fresh and exhausted air.
As an option, the unit could be produced with F7 fine filter, which leads to reduction of the external pressure of the unit.

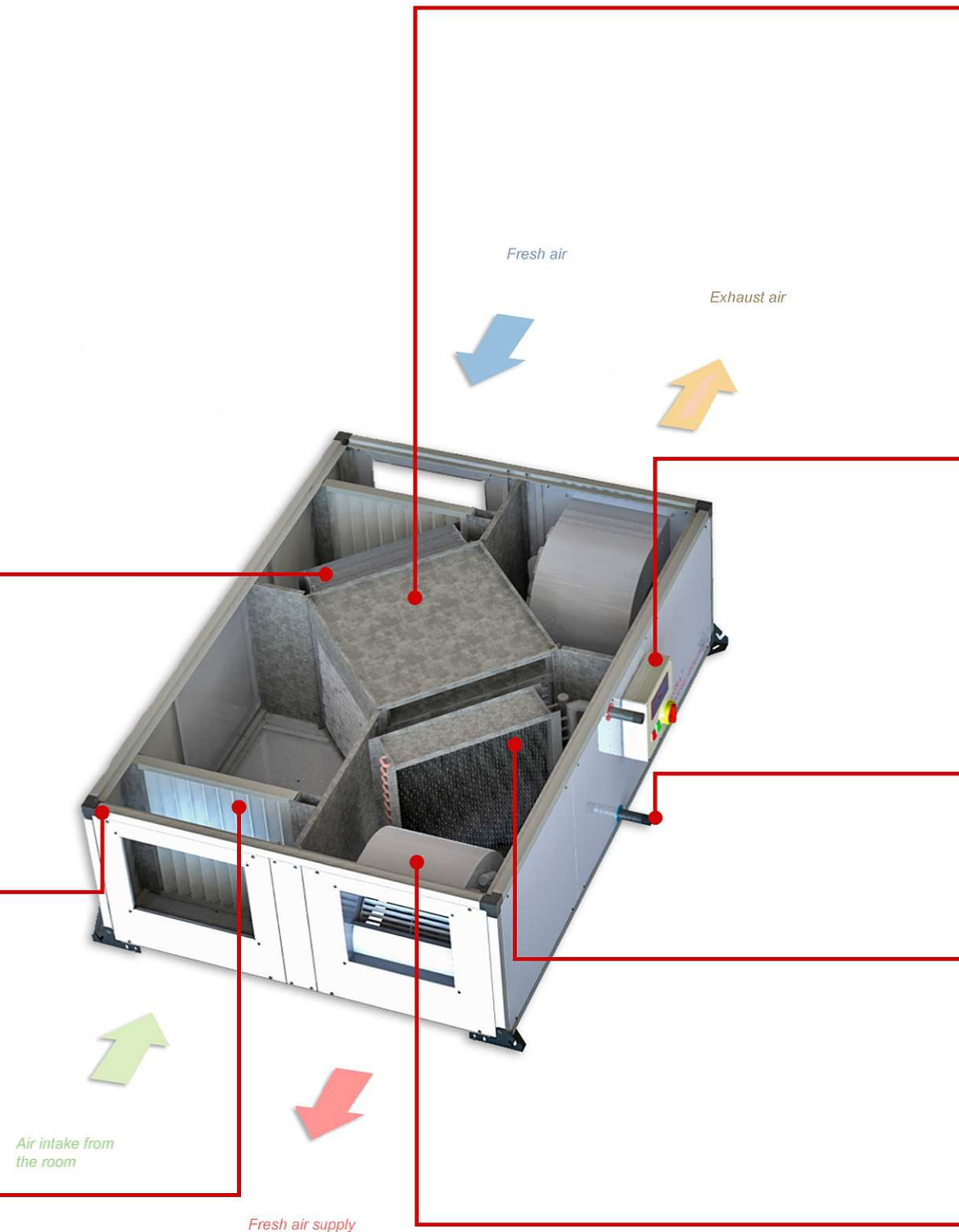

Plate heat exchanger - recuperator

Manufactured of aluminium lamellas.
Provides heat exchange between fresh and exhausted air, with efficiency **up to 65%**.
There is no odors (smells) and moisture transfer between the two streams.
Operating temperature from -40°C to $+90^{\circ}\text{C}$.
Heat recovery blocks are manufactured with two types of heat exchangers - AL (fin space 5/8mm) and AL+ (fin space 4/6mm).

Electric board

Power supply of fans, heaters and bypass actuator are led to an electrical board, installed outside the unit's housing. In this board are also included sensors for temperature, pressure and programmable controller. For more information about the controller - see p.16-17.

Drainage

Integrated drain tray with 1/2" connector help to lead off the moisture, that condensate during the heat exchange.

Water heat exchanger (option)

Heat exchanger, type "air-water", made of copper tubes with aluminium lamellas allows additional heating of the fresh air.
* On request the cooling mode can be arranged.

Fans

Double inlet direct driven centrifugal fans with air flow between 250 - 8500 m³/h. All motors are designed according to the requirements of Ecodesign Directive 2009/125/EC (ErP Directive).
All fans are equipped with single or three speed motor (for more information see p.12-14).

Product range

Product range of 9 models cover air flows from 250 up to 8500 m3/h.

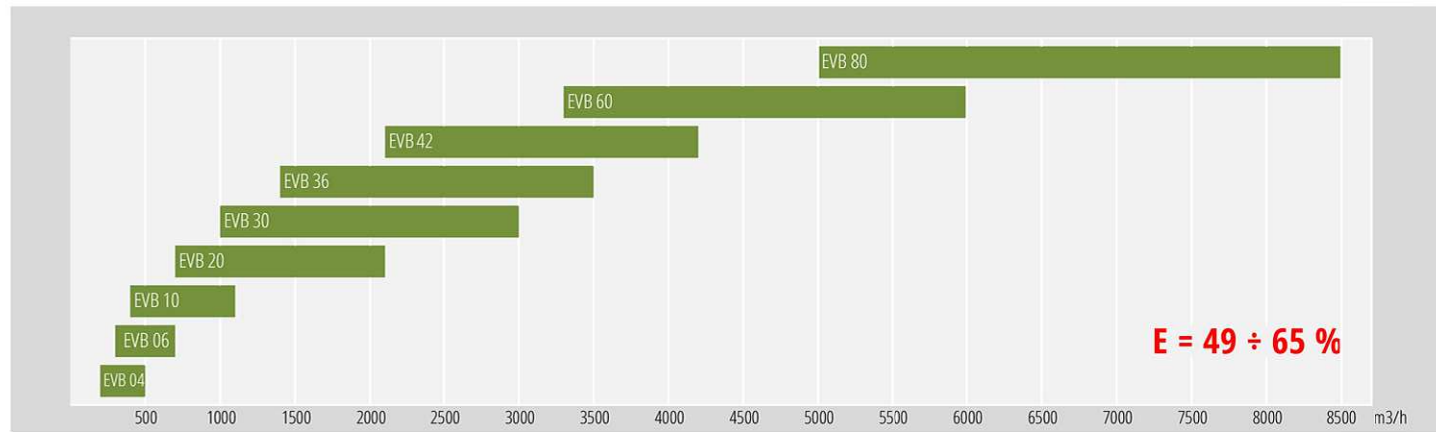

Heat recovery units could be designed as monoblock (04-42) or as split systems (60-80), allowing easy transport and installation. According to the room specification they could be produced for horizontal or vertical installation.

Model / Size	04	06	10	20	30	36	42	60	80
EVB AL/AL+ H	●	●	●	●	●	●	●	●	●
EVB AL/AL+ H-BS	●	●	●	●	●	●	●	●	●
EVB AL/AL+ H-HBS	●	●	●	●	●	●	●	●	●
EVB AL/AL+ V	●	●	●	●	●	●	●	●	●
EVB AL/AL+ V-BS	●	●	●	●	●	●	●	●	●
EVB AL/AL+ V-HBS	●	●	●	●	●	●	●	●	●

● Monoblock models
● Split models

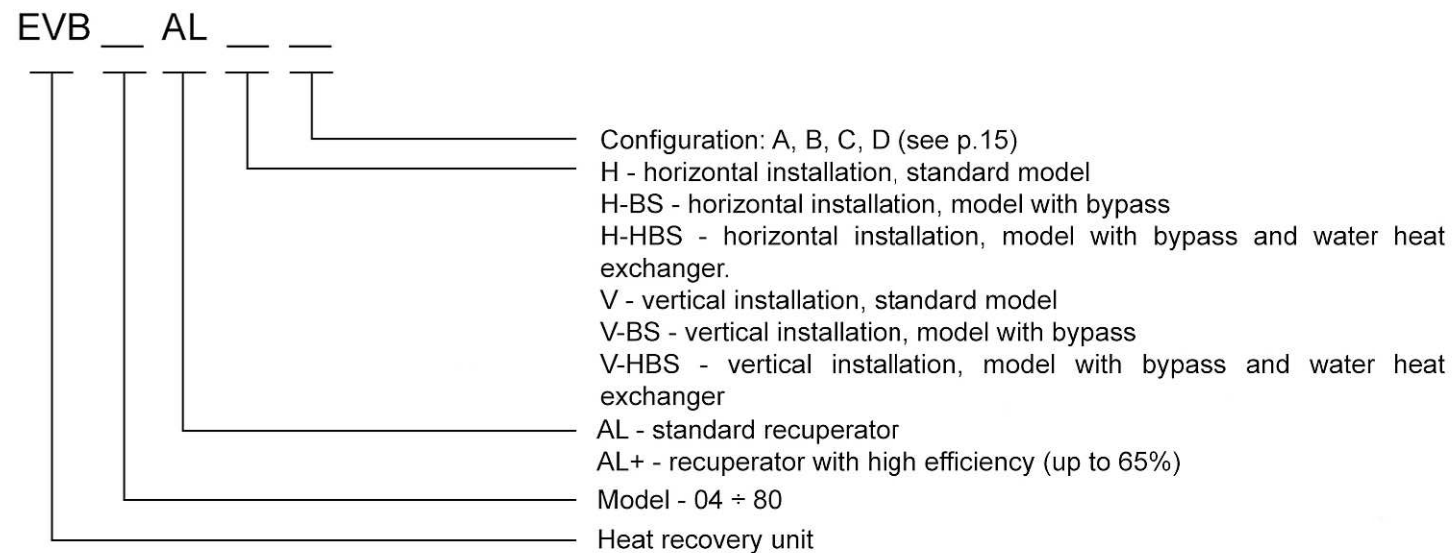

Why the heat recovery is important?



Heat recovery in ventilation is exceptionally profitable investment. It becomes more clear from the comparison between system without and with heat recovery exchanger. The payback period is between 1 and 3 years, depending on the running time of the system.

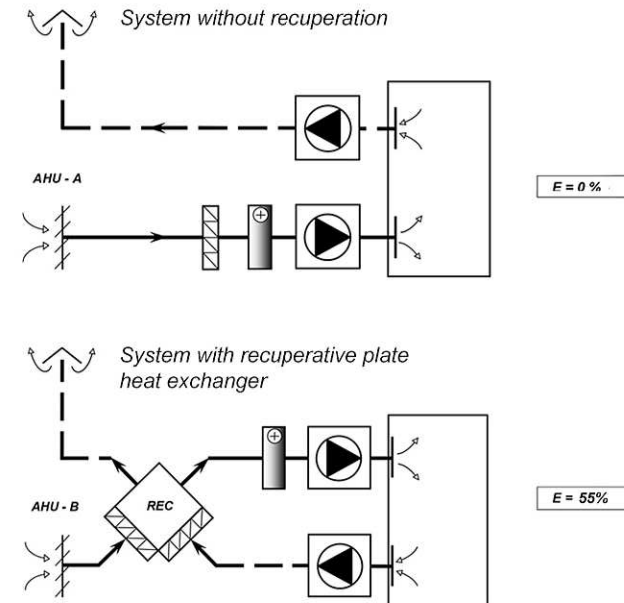

Crossflow heat exchanger REC AL
Efficiency 49 - 65%

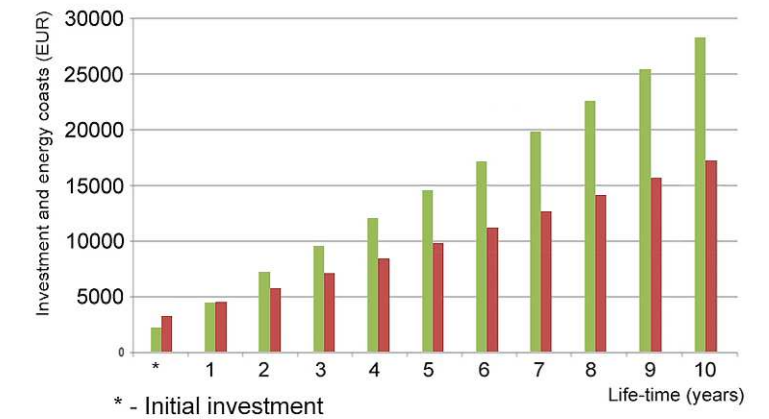
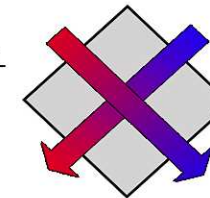

■ S1 - System without heat recovery
■ S2 - System with 55% heat recovery

The graphic shows the initial investment and the accumulation of energy costs, according to the following conditions:
 - 10 hours running time of the system
 - climate data for Sofia
 - 10 years operation period

Annual division of energy costs

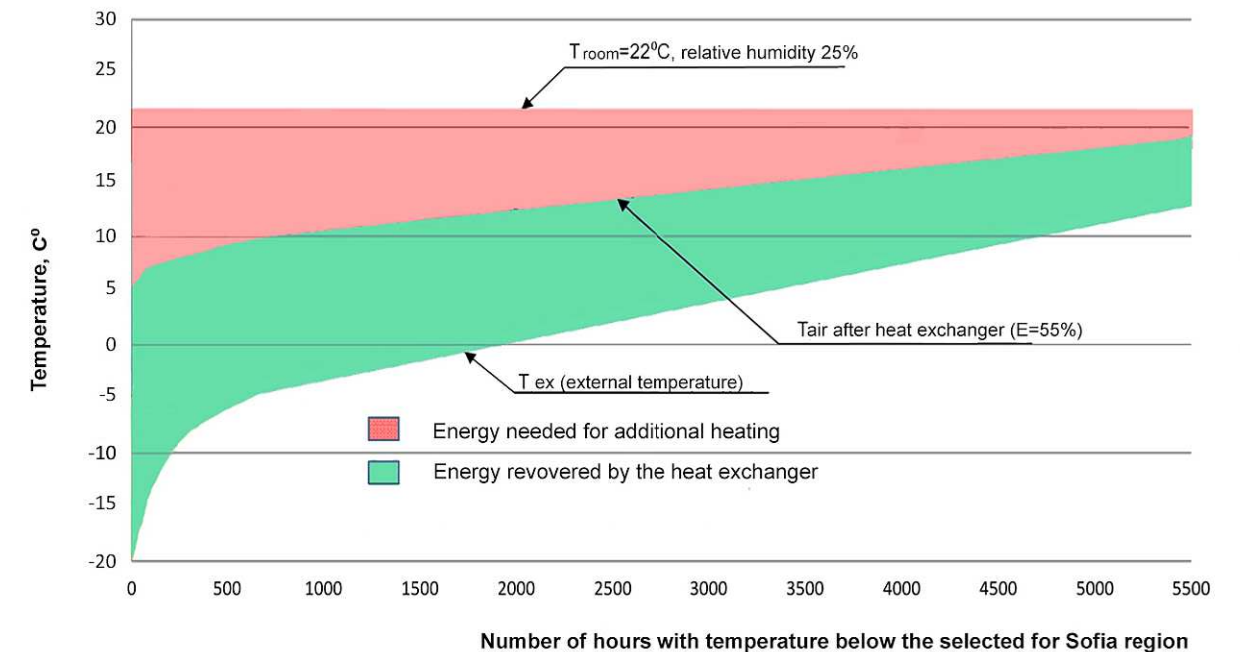

Dimensions

EVB __AL/AL+ H

04 06 10 20 30 36 42

Horizontal installation
Standard model
Monoblock

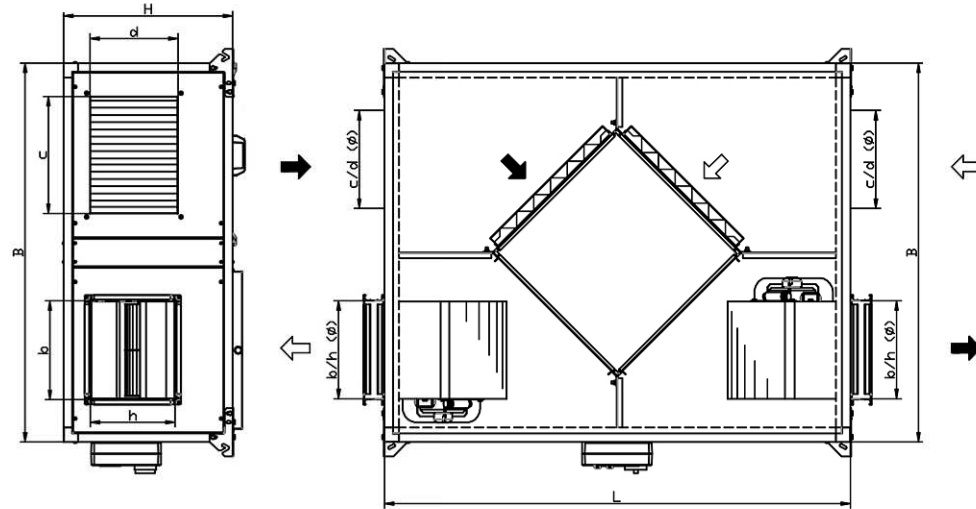

Model	Air flow [m3/h]	B [mm]	H [mm]	L [mm]	b [mm]	h [mm]	ØD [mm]	c [mm]	d [mm]	Weight [kg]
EVB 04 AL/AL+	500	1050	280	1050	250	150	200	250	150	51
EVB 06 AL/AL+	700	1050	300	1050	300	200	250	300	200	57
EVB 10 AL/AL+	1000	1050	380	1050	300	200	250	300	200	66
EVB 20 AL/AL+	2000	1060	480	1500	235	260	315	300	300	134
EVB 30 AL/AL+	3000	1300	580	1600	335	290	355	400	300	156
EVB 36 AL/AL+	3500	1300	780	1600	335	290	355	400	400	195
EVB 42 AL/AL+	4400	1300	900	1600	335	290	355	500	400	253

EVB __AL/AL+ V

04 06 10 20 30 36 42

Vertical installation
Standard model
Monoblock

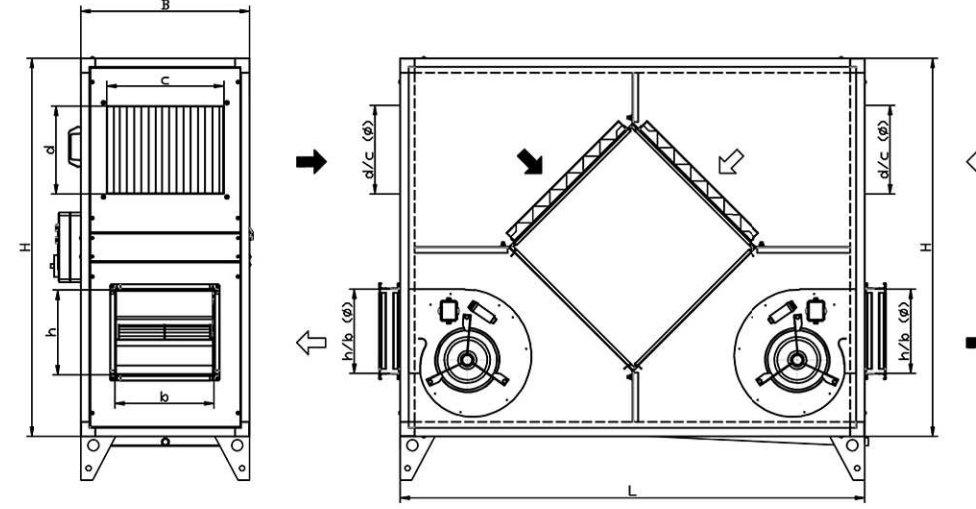

Model	Air flow [m3/h]	B [mm]	H [mm]	L [mm]	b [mm]	h [mm]	ØD [mm]	c [mm]	d [mm]	Weight [kg]
EVB 04 AL/AL+	500	280	1000	1000	250	150	200	250	150	51
EVB 06 AL/AL+	700	300	1000	1000	300	200	250	300	200	57
EVB 10 AL/AL+	1000	380	1000	1000	300	200	250	300	200	66
EVB 20 AL/AL+	2000	510	1060	1500	235	260	315	300	300	136
EVB 30 AL/AL+	3000	580	1300	1600	335	290	355	400	300	156
EVB 36 AL/AL+	3500	780	1300	1600	335	290	355	400	400	195
EVB 42 AL/AL+	4400	900	1300	2000	335	290	355	500	400	253

EVB __AL/AL+ H

60 80

Horizontal installation
Standard model
Split unit

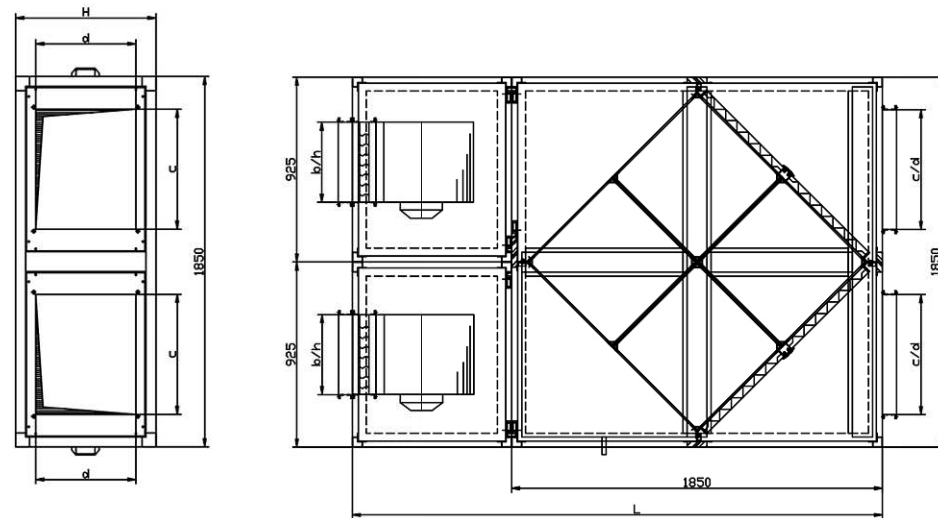

Model	Air flow [m3/h]	B [mm]	H [mm]	L [mm]	b [mm]	h [mm]	ØD [mm]	c [mm]	d [mm]	Weight [kg]
EVB 60 AL/AL+	6000	1850	800	2550	310	340	-	700	600	397
EVB 80 AL/AL+	8000	1850	1000	2650	475	400	-	700	700	563

Side panels of the supply and suction side of the unit are interchangeable.
In this way, it is possible to make different configurations (see p.15). As standard this units are produced with rectangular connections.
We reserve the right to introduce alternations both in design and technical data without prior notice, due to continued product development.

EVB __AL/AL+ V

60 80

Vertical installation
Standard model
Split unit

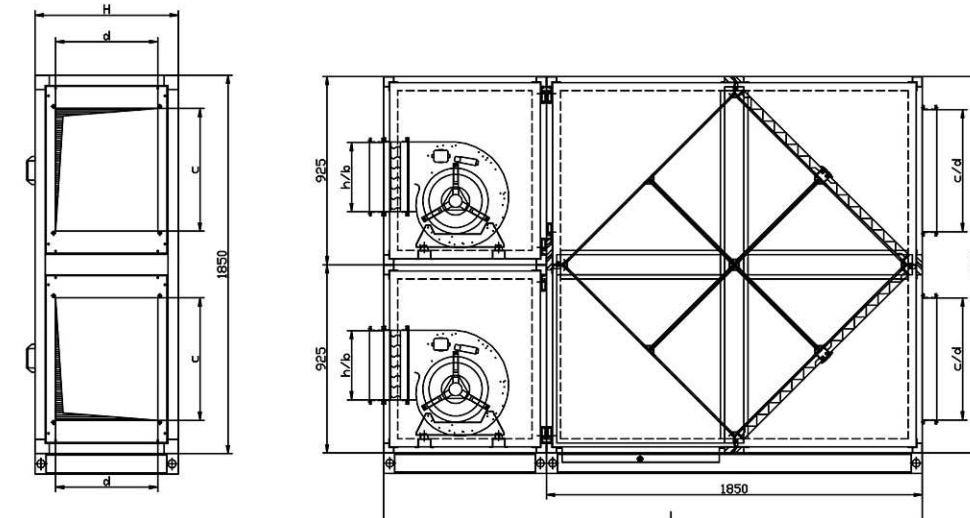

Model	Air flow [m3/h]	B [mm]	H [mm]	L [mm]	b [mm]	h [mm]	ØD [mm]	c [mm]	d [mm]	Weight [kg]
EVB 60 AL/AL+	6000	800	1850	2550	310	340	-	700	600	397
EVB 80 AL/AL+	8000	1000	1850	2650	475	400	-	700	700	563

Side panels of the supply and suction side of the unit are interchangeable.
In this way, it is possible to make different configurations (see p.15). As standard this units are produced with rectangular connections.
We reserve the right to introduce alternations both in design and technical data without prior notice, due to continued product development.

Dimensions

EVB __AL/AL+ H-BS

04 06 10 20 30 36 42

Horizontal installation
Model with bypass
Monoblock

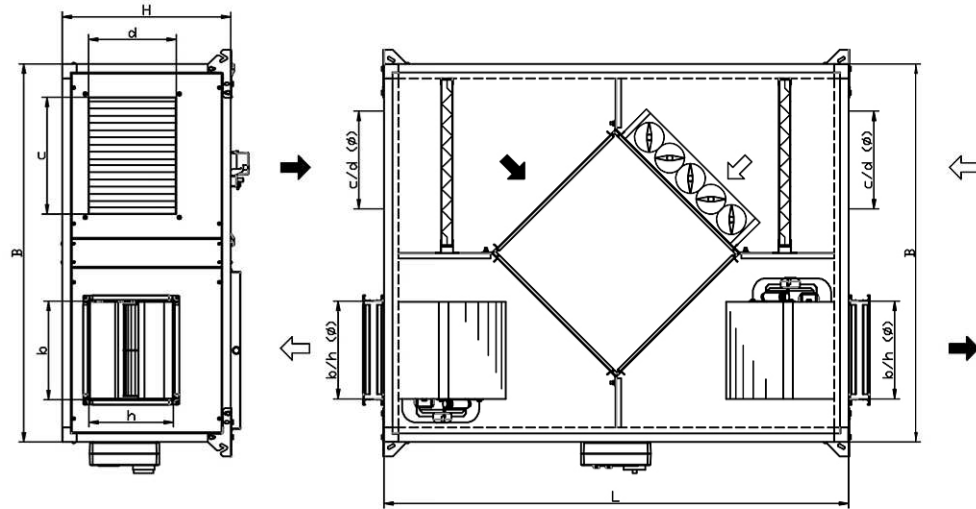

Model	Air flow [m3/h]	B [mm]	H [mm]	L [mm]	b [mm]	h [mm]	ØD [mm]	c [mm]	d [mm]	Weight [kg]
EVB 04 AL/AL+	500	1050	380	1200	250	150	200	250	150	62
EVB 06 AL/AL+	700	1050	400	1200	300	200	250	300	200	69
EVB 10 AL/AL+	1000	1050	520	1200	300	200	250	300	200	76
EVB 20 AL/AL+	2000	1060	650	1500	235	260	315	300	300	137
EVB 30 AL/AL+	3000	1300	750	1600	335	290	355	400	300	164
EVB 36 AL/AL+	3500	1300	950	1600	335	290	355	400	400	228
EVB 42 AL/AL+	4400	1300	1150	1600	335	290	355	400	400	287

EVB __AL/AL+ V-BS

04 06 10 20 30 36 42

Vertical installation
Model with bypass
Monoblock

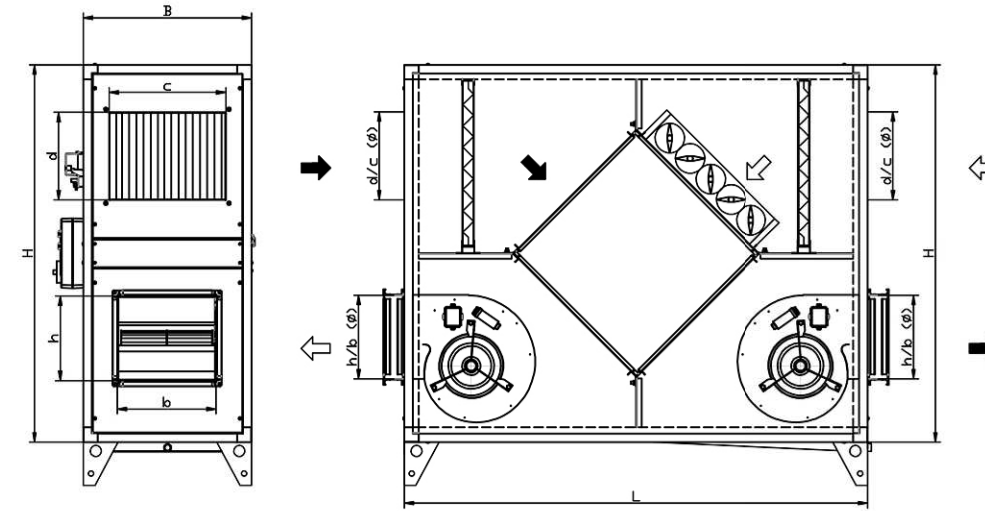

Model	Air flow [m3/h]	B [mm]	H [mm]	L [mm]	b [mm]	h [mm]	ØD [mm]	c [mm]	d [mm]	Weight [kg]
EVB 04 AL/AL+	500	380	1050	1200	250	150	200	250	150	62
EVB 06 AL/AL+	700	400	1050	1200	300	200	250	300	200	69
EVB 10 AL/AL+	1000	520	1050	1200	300	200	250	300	200	76
EVB 20 AL/AL+	2000	650	1060	1500	235	260	315	300	300	137
EVB 30 AL/AL+	3000	750	1300	1600	335	290	355	400	300	164
EVB 36 AL/AL+	3500	950	1300	1600	335	290	355	400	400	228
EVB 42 AL/AL+	4400	1150	1300	2000	335	290	355	500	400	287

EVB __AL/AL+ H-BS

60 80

Horizontal installation
Model with bypass
Split unit

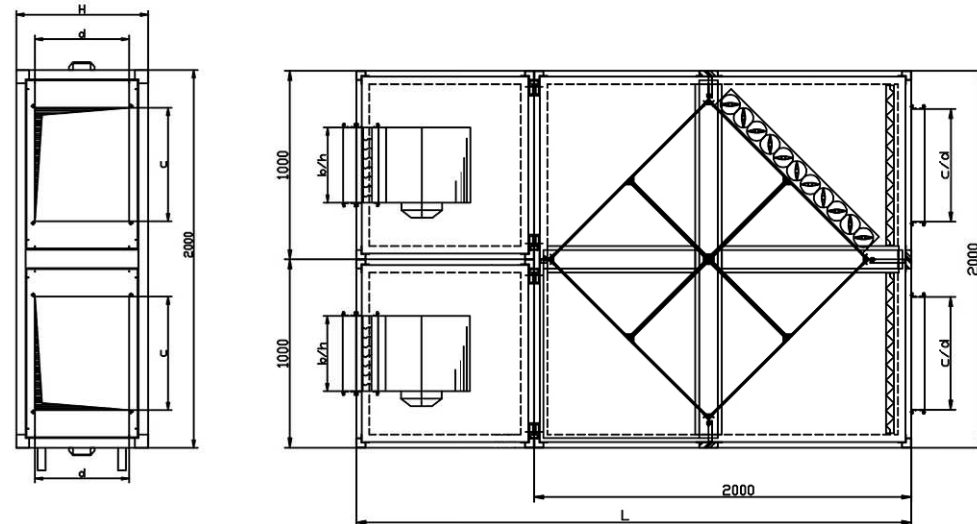

Model	Air flow [m3/h]	B [mm]	H [mm]	L [mm]	b [mm]	h [mm]	ØD [mm]	c [mm]	d [mm]	Weight [kg]
EVB 60 AL/AL+	6000	2000	1100	3000	310	340	-	700	600	547
EVB 80 AL/AL+	8000	2000	1300	3100	475	400	-	700	700	713

Side panels of the supply and suction side of the unit are interchangeable.
In this way, it is possible to make different configurations (see p.15). As standard this units are produced with rectangular connections.
We reserve the right to introduce alternations both in design and technical data without prior notice, due to continued product development.

EVB __AL/AL+ V-BS

60 80

Vertical installation
Model with bypass
Split unit

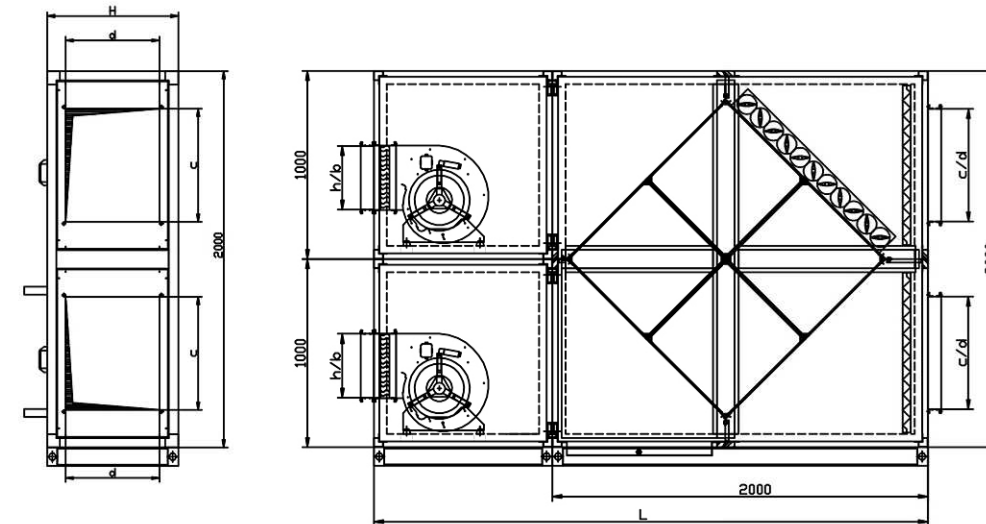

Model	Air flow [m3/h]	B [mm]	H [mm]	L [mm]	b [mm]	h [mm]	ØD [mm]	c [mm]	d [mm]	Weight [kg]
EVB 60 AL/AL+	6000	1100	2000	3000	310	340	-	700	600	547
EVB 80 AL/AL+	8000	1300	2000	3100	475	400	-	700	700	713

Side panels of the supply and suction side of the unit are interchangeable.
In this way, it is possible to make different configurations (see p.15). As standard this units are produced with rectangular connections.
We reserve the right to introduce alternations both in design and technical data without prior notice, due to continued product development.

Dimensions

EVB __AL/AL+ H-HBS

06 10 20 30 36 42

Horizontal installation
Model with bypass and
"air-water" heat exchanger
Monoblock

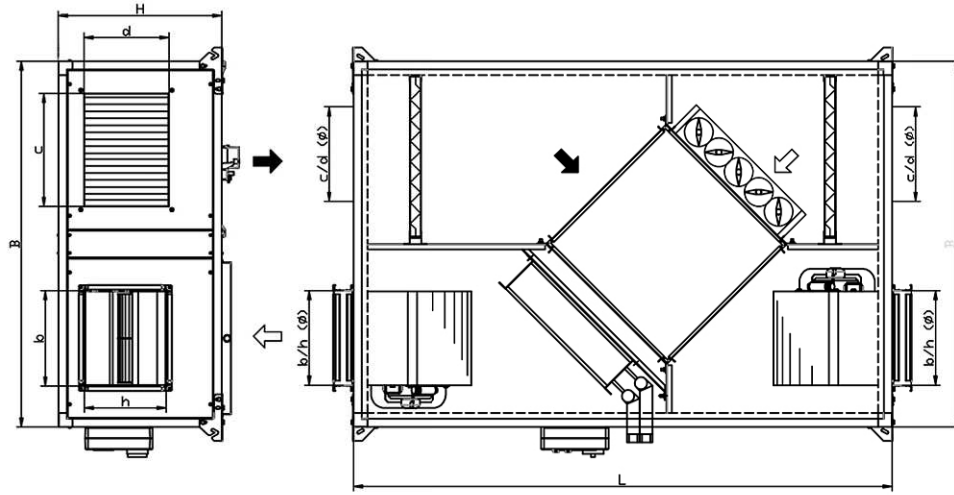

Model	Air flow [m3/h]	B [mm]	H [mm]	L [mm]	b [mm]	h [mm]	ØD [mm]	c [mm]	d [mm]	Weight [kg]
EVB 04 AL/AL+	500	1050	380	1600	250	150	200	250	150	85
EVB 06 AL/AL+	700	1050	400	1600	300	200	250	300	200	88
EVB 10 AL/AL+	1000	1050	520	1600	300	200	250	300	200	95
EVB 20 AL/AL+	2000	1200	650	1900	235	260	315	300	300	167
EVB 30 AL/AL+	3000	1300	750	1900	335	290	355	400	300	194
EVB 36 AL/AL+	3500	1300	950	1900	335	290	355	400	400	256
EVB 42 AL/AL+	4400	1450	1150	2000	335	290	355	500	400	326

EVB __AL/AL+ V-HBS

06 10 20 30 36 42

Vertical installation
Model with bypass and
"air-water" heat exchanger
Monoblock

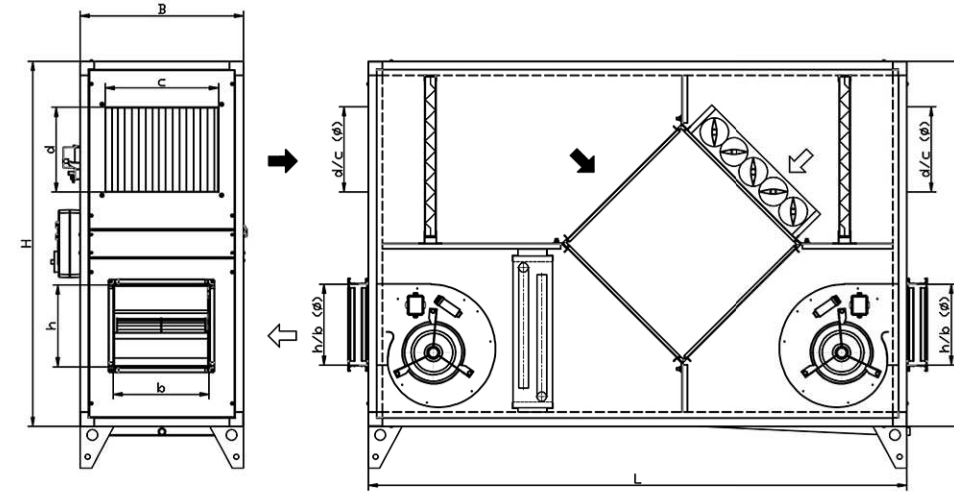

Model	Air flow [m3/h]	B [mm]	H [mm]	L [mm]	b [mm]	h [mm]	ØD [mm]	c [mm]	d [mm]	Weight [kg]
EVB 04 AL/AL+	500	560	1050	1600	250	150	200	250	150	93
EVB 06 AL/AL+	700	560	1050	1600	300	200	250	300	200	95
EVB 10 AL/AL+	1000	560	1050	1600	300	200	250	300	200	98
EVB 20 AL/AL+	2000	650	1200	1900	235	260	315	300	300	167
EVB 30 AL/AL+	3000	760	1300	1900	335	290	355	400	300	196
EVB 36 AL/AL+	3500	950	1300	1900	335	290	355	400	400	256
EVB 42 AL/AL+	4400	1150	1450	2000	335	290	355	500	400	326

EVB __AL/AL+ H-HBS

60 80

Horizontal installation
Model with bypass and
"air-water" heat exchanger
Split unit

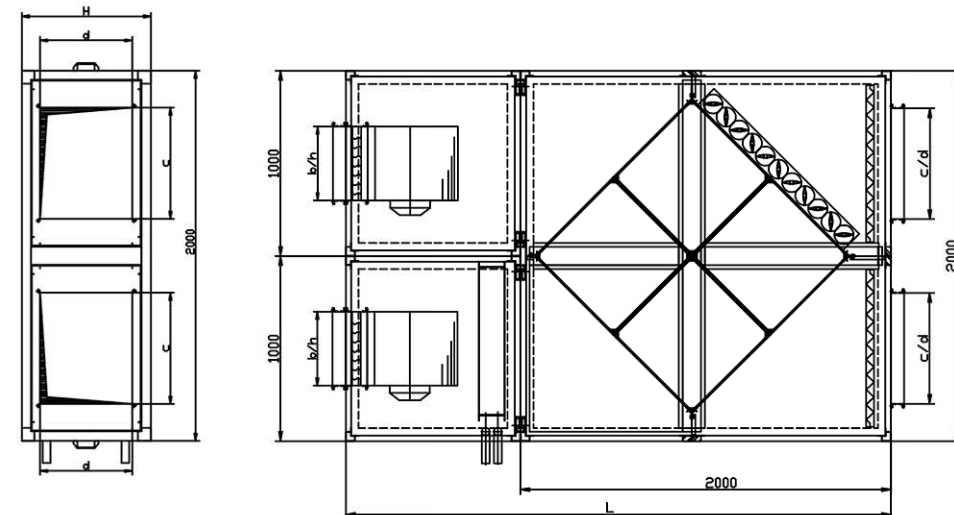

Model	Air flow [m3/h]	B [mm]	H [mm]	L [mm]	b [mm]	h [mm]	ØD [mm]	c [mm]	d [mm]	Weight [kg]
EVB 60 AL/AL+	6000	2000	1100	3000	310	340	-	700	600	577
EVB 80 AL/AL+	8000	2000	1300	3100	475	400	-	700	700	743

Side panels of the supply and suction side of the unit are interchangeable.
In this way, it is possible to make different configurations (see p.15). As standard this units are produced with rectangular connections.
We reserve the right to introduce alternations both in design and technical data without prior notice, due to continued product development.

EVB __AL/AL+ V-HBS

60 80

Vertical installation
Model with bypass and
"air-water" heat exchanger
Split unit

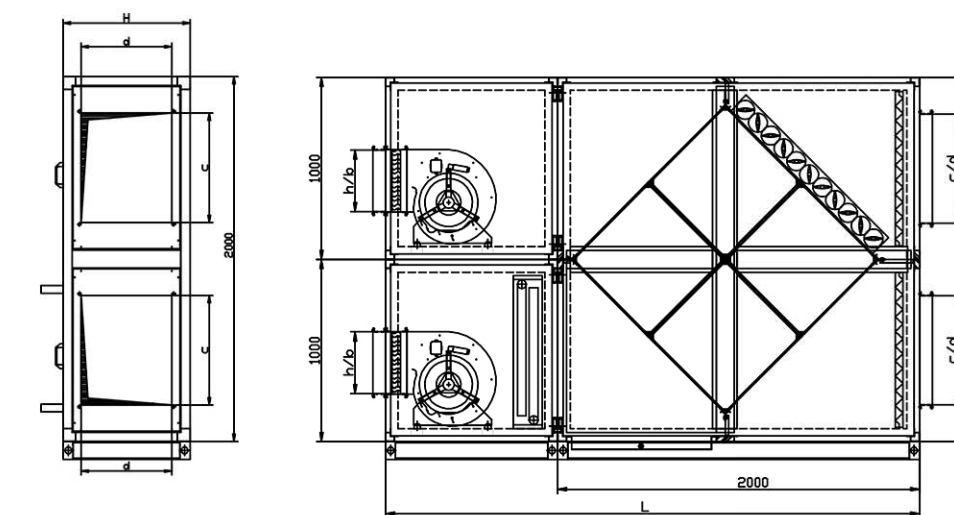

Model	Air flow [m3/h]	B [mm]	H [mm]	L [mm]	b [mm]	h [mm]	ØD [mm]	c [mm]	d [mm]	Weight [kg]
EVB 60 AL/AL+	6000	1100	2000	3000	310	340	-	700	600	577
EVB 80 AL/AL+	8000	1300	2000	3100	475	400	-	700	700	743

Side panels of the supply and suction side of the unit are interchangeable.
In this way, it is possible to make different configurations (see p.15). As standard this units are produced with rectangular connections.
We reserve the right to introduce alternations both in design and technical data without prior notice, due to continued product development.

Technical data

EVB 04 AL/AL+

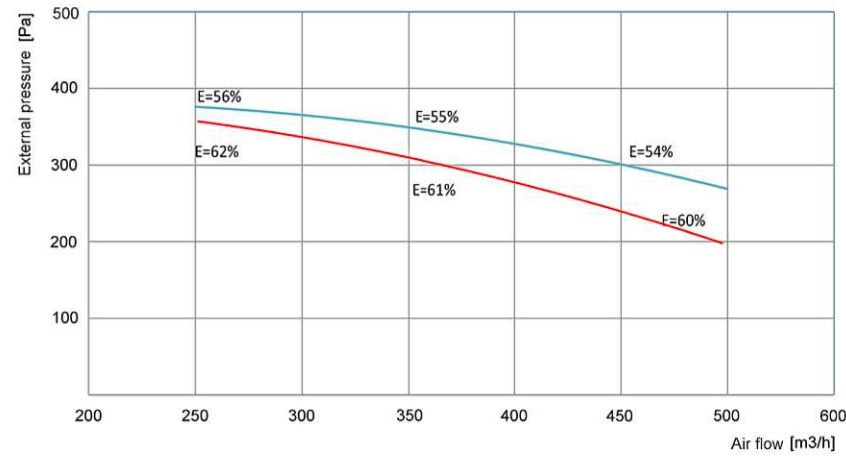

Absorbed power [W]	2x180
Voltage [V]	230
Max. absorbed current [A]	2x0.95
Operation temperature [C]	-20° ÷ 40°
Protection	IP44
Motor control	1V

1V – 1 speed motor
 — Recuperativ heat exchanger AL
 — Recuperativ heat exchanger AL+

EVB 20 AL/AL+

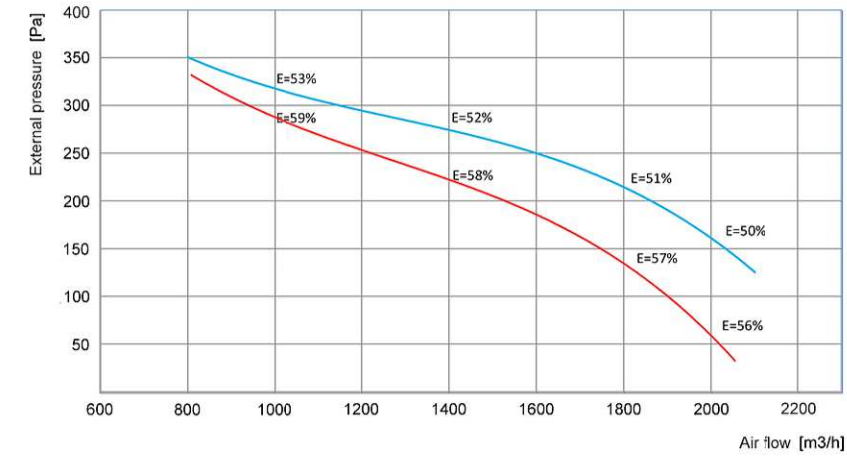

Absorbed power [W]	2x373
Voltage [V]	230
Max. absorbed current [A]	2x3.65
Operation temperature [C]	-20° ÷ 40°
Protection	IP 20
Motor control	VR

VR – Speed controllable motor by tension
 — Recuperativ heat exchanger AL
 — Recuperativ heat exchanger AL+

EVB 06 AL/AL+

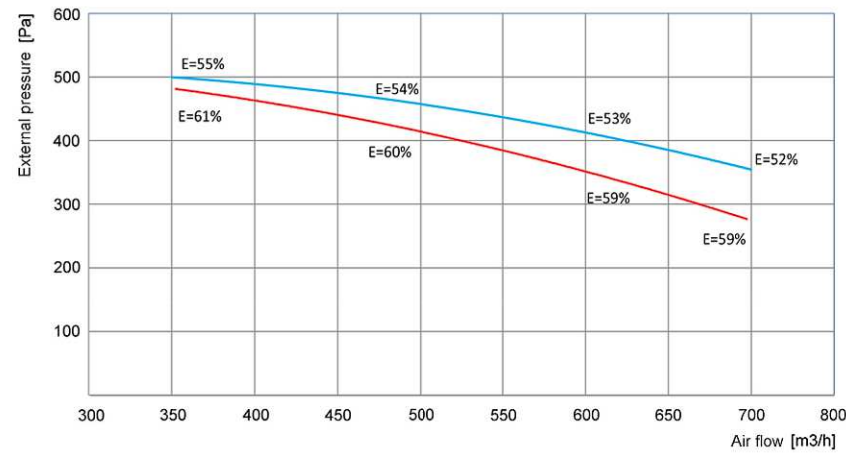

Absorbed power [W]	2x300
Voltage [V]	230
Max. absorbed current [A]	2x1.38
Operation temperature [C]	-20° ÷ 55°
Protection	IP44
Motor control	VR

VR – Speed controllable motor by tension
 — Recuperativ heat exchanger AL
 — Recuperativ heat exchanger AL+

EVB 30 AL/AL+

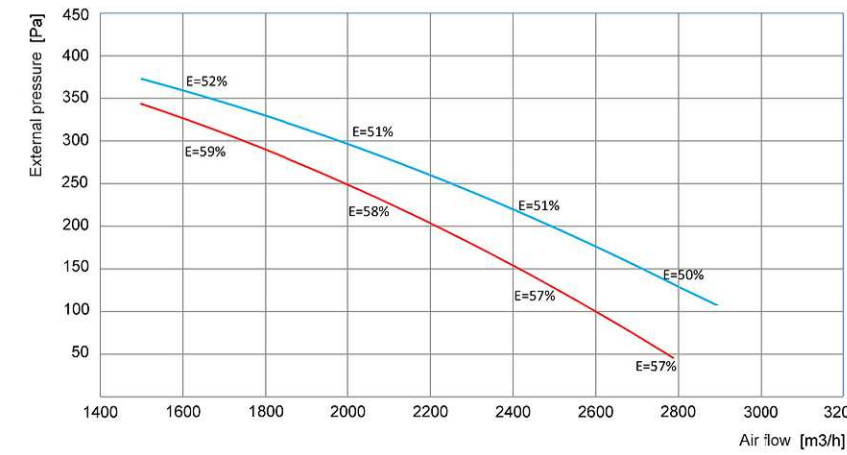

Absorbed power [W]	2x550
Voltage [V]	230
Max. absorbed current [A]	2x4.30
Operation temperature [C]	-20° ÷ 40°
Protection	IP 44
Motor control	VR

VR – Speed controllable motor by tension
 — Recuperativ heat exchanger AL
 — Recuperativ heat exchanger AL+

EVB 10 AL/AL+

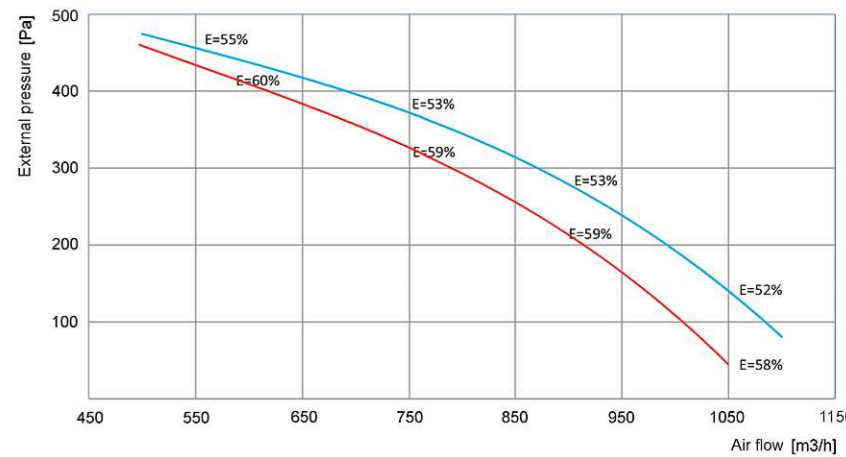

Absorbed power [W]	2x300
Voltage [V]	230
Max. absorbed current [A]	2x1.38
Operation temperature [C]	-20° ÷ 55°
Protection	IP 44
Motor control	VR

VR – Speed controllable motor by tension
 — Recuperativ heat exchanger AL
 — Recuperativ heat exchanger AL+

EVB 36 AL/AL+

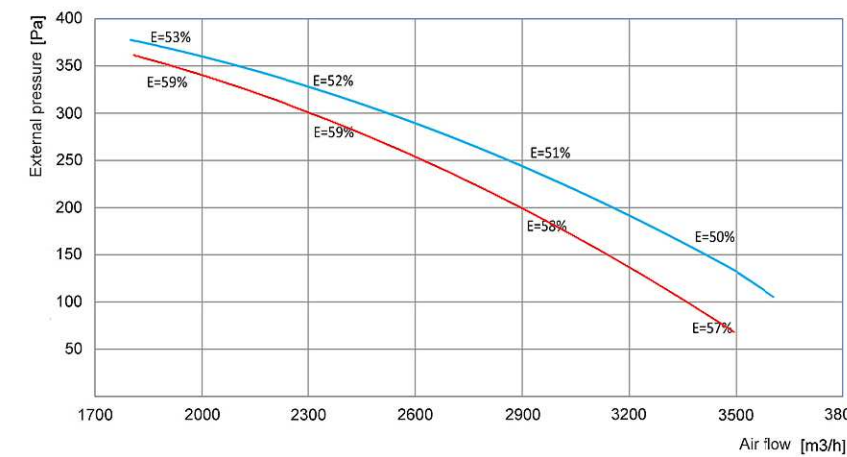

Absorbed power [W]	2x550
Voltage [V]	230
Max. absorbed current [A]	2x4.30
Operation temperature [C]	-20° ÷ 40°
Protection	IP 44
Motor control	VR

VR – Speed controllable motor by tension
 — Recuperativ heat exchanger AL
 — Recuperativ heat exchanger AL+

Note: Efficiency data are valid at equal mass flows of both flows and at 22°C and 25% relative humidity of the exhaust air. If the relative humidity rised, the efficiency will increase with 3÷5%.

We reserve the right to introduce alternations both in design and technical data without prior notice, due to continued product development.

Note: Efficiency data are valid at equal mass flows of both flows and at 22°C and 25% relative humidity of the exhaust air. If the relative humidity rised, the efficiency will increase with 3÷5%.

We reserve the right to introduce alternations both in design and technical data without prior notice, due to continued product development.

Technical data

Configurations

EVB 42 AL/AL+

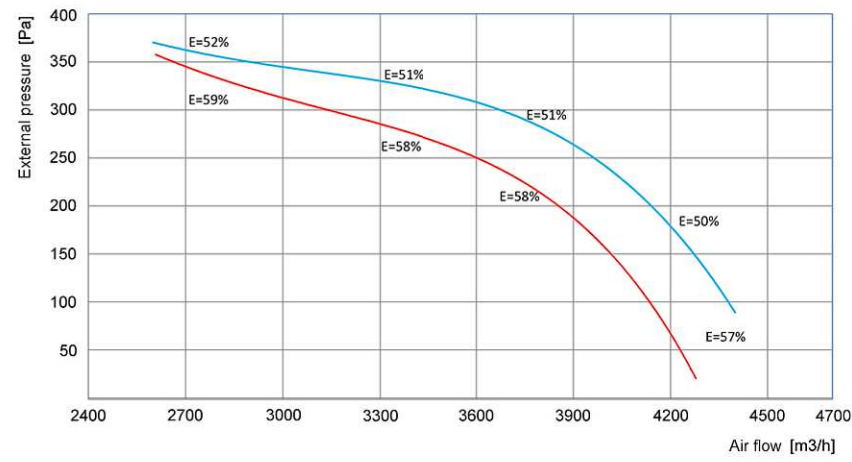

Absorbed power [W]	2x750
Voltage [V]	230
Max. absorbed current [A]	2x7.80
Operation temperature [C]	-20° ÷ 40°
Protection	IP 20
Motor control	3V

3V – 3 speed motor
 — Recuperativ heat exchanger AL
 — Recuperativ heat exchanger AL+

EVB 60 AL/AL+

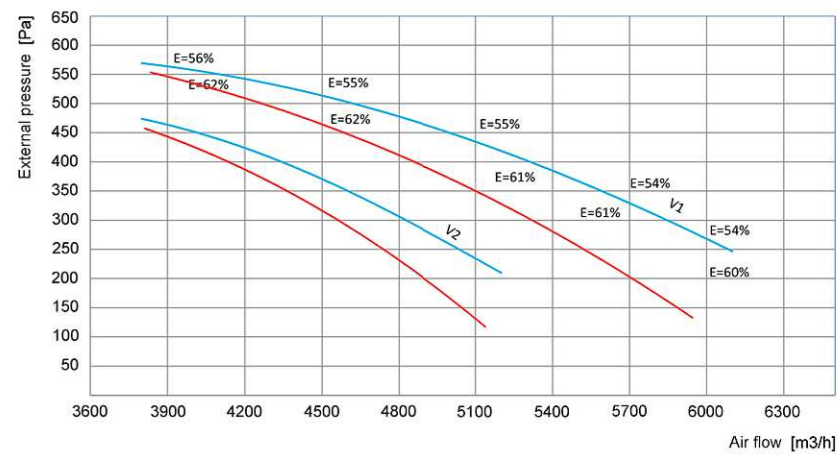

Absorbed power [W]	2x1500
Voltage [V]	400
Max. absorbed current [A]	2x5.00
Operation temperature [C]	-20° ÷ 40°
Protection	IP 20
Motor control	2V

2V – 2 speed motor
 — Recuperativ heat exchanger AL
 — Recuperativ heat exchanger AL+

EVB 80 AL/AL+

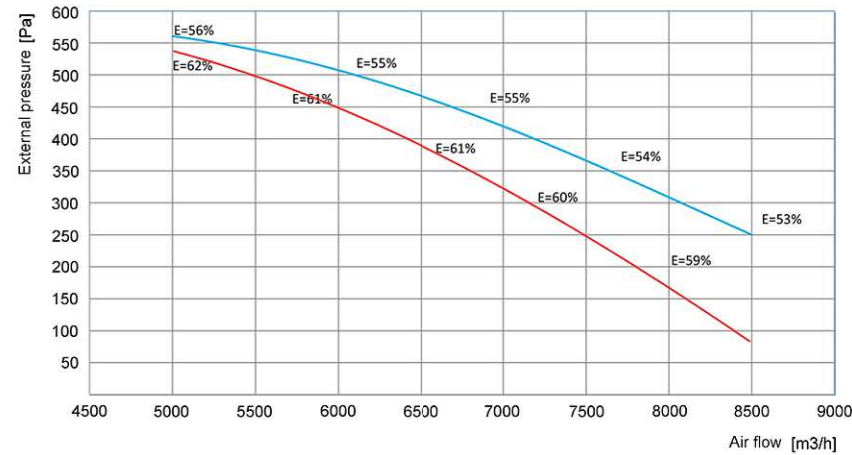

Absorbed power [W]	2x2200
Voltage [V]	400
Max. absorbed current [A]	2x8.80
Operation temperature [C]	-20° ÷ 40°
Protection	IP 55
Motor control	1V

1V – 1 speed motor
 — Recuperativ heat exchanger AL
 — Recuperativ heat exchanger AL+

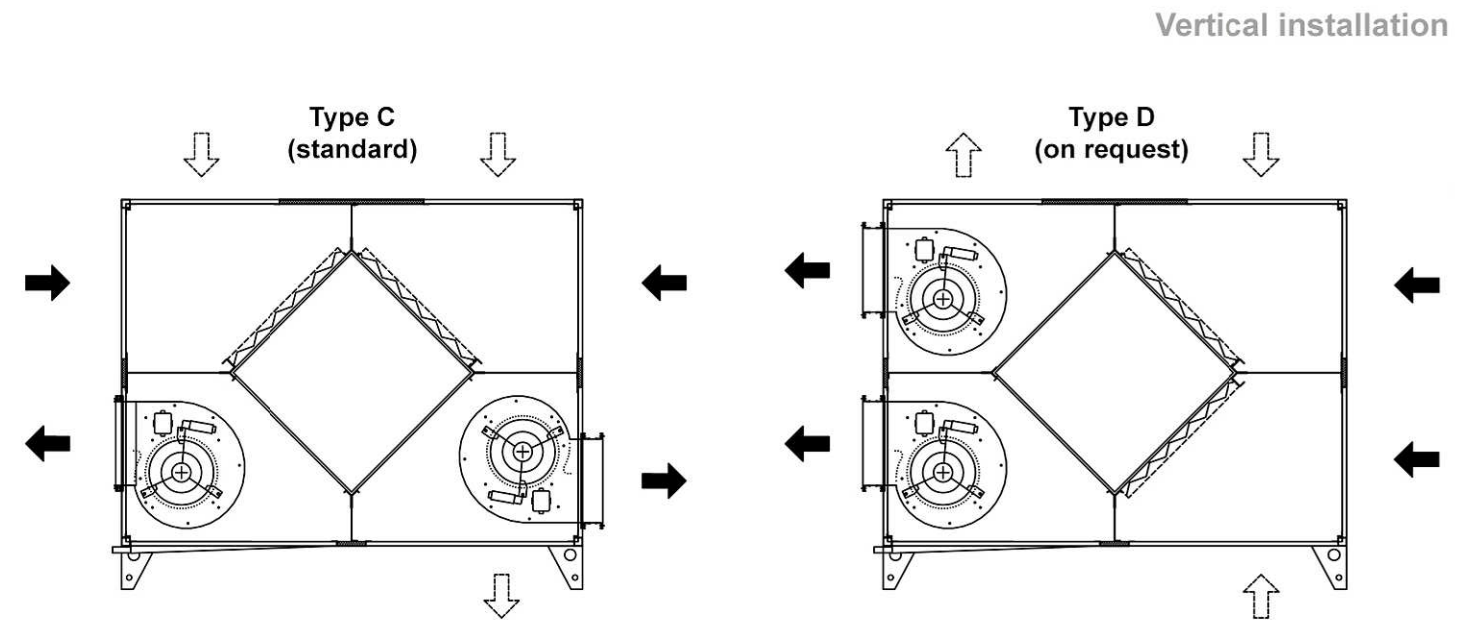
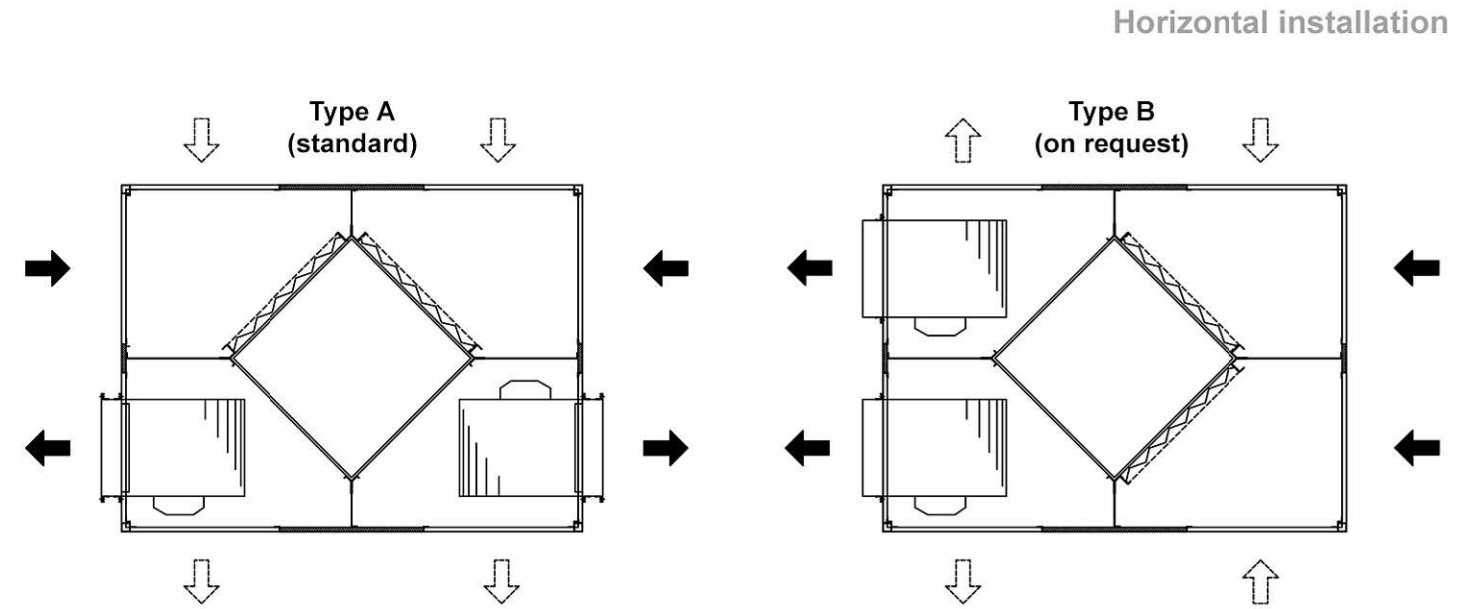

Note: The configurations mentioned above (A to D) are not relevant for models EVB 60 AL/AL+ and EVB 80 AL/AL+. For more information, please contact the manufacturer.

Note: Efficiency data are valid at equal mass flows of both flows and at 22°C and 25% relative humidity of the exhaust air. If the relative humidity rised, the efficiency will increase with 3+5%.

We reserve the right to introduce alternations both in design and technical data without prior notice, due to continued product development.

We reserve the right to introduce alternations both in design and technical data without prior notice, due to continued product development.

Acoustic data LwA (dB(A))

TANGRA SMART

	63	125	250	500	1000	2000	4000	8000
EVB 04 AL/AL+	47	55	56	65	68	70	66	63
EVB 06 AL/AL+	48	56	58	66	70	71	67	65
EVB 10 AL/AL+	46	53	58	65	68	67	66	58
EVB 20 AL/AL+	48	58	67	70	75	74	71	62
EVB 30 AL/AL+	48	57	65	71	75	74	72	63
EVB 36 AL/AL+	51	63	69	71	75	75	72	64
EVB 42 AL/AL+	51	63	69	71	75	75	72	64
EVB 60 AL/AL+	56	67	72	77	78	80	77	70
EVB 80 AL/AL+	56	67	72	77	78	80	77	70

These values are measured at the fan exit at maximum speed.

Control

High efficiency heat recovery units offer the following options for control:

TANGRA ETY/STL/MTV

- Only fan speed control (two controls per unit)
- Bypass valve operates automatically, according to signals T1 и T2.
- The pre-heater turns on automatically on signal for freezing.

Speed controllers ETY ETY1.5 - up to 1.5A
 ETY2.5 - up to 2.5A

Speed controllers STL STL5 - up to 5A
 STL10 - up to 10A

Speed controllers MTV From 0 to 10V, for EC motors.



ETY controller



STL controller



SQA controller

SQA

- Air quality sensor with integrated timer. The unit allows to set a level of pollution of the environment, when the fan turns on and duration of the operation period.
- Bypass valve operates automatically, according to signals T1 и T2.
- The pre-heater turns on automatically on signal for freezing.



The control of the heat recovery ventilation can be performed by different devices using systems with Android or iOS (smart phones or tablets).

The controller use wireless signal WiFi and through it can be reached by different devices. It can be connected to internet by cable or wireless and can be controlled from a distance.

- Control of the system - On/Off and Auto/Manual.
- Control of the system through humidistat (rH) or air quality sensor (CO2) in Auto mode.
- The fans can be controlled smoothly from 30% to 100%. It is possible to control both fans together or separately.
- By-pass - automatically open the flap at a set temperature and close it at a set temperature.
- Control of the additional electric or water heater. It can control smoothly the electric heater or the valve of the water heater, in order to satisfy the customer needs for supply air temperature.
- Signal for dirty air filters - automatic signal when the fresh air or exhaust air filter is dirty and in the same time it changes the color of the filter that is dirty.
- Visualization of the 5 temperatures of the air in the different parts of the unit.
- Visualization of the approximately saved energy from the unit.



Possibility to manage more than one unit

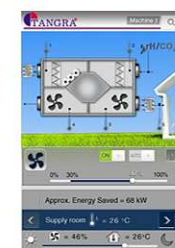

Unit is offline

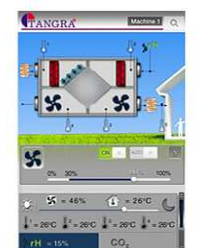

Setting of parameters

Installation and accessories

The calculation of fresh air volume is based on the room area, number of people and room categorie.

Categorie	Fresh air quantity per person [m ³ /h]	Air volume for 1m ² floor area [m ³ /h]
A	36.0	6.1 ÷ 57.8
B	25.2	4.3 ÷ 40.3
C	14.4	2.5 ÷ 23.0

The lowest requirements of fresh air per 1sq.m. are in open space office areas and the highest are in high halls, kindergarden and restaurants.

Accessories

Sound attenuator - with rectangular or round shape. Reduce the noise level, transferred by the duct system.



Air filter F7 - As a standard, the unit is produces with filter G4 EN 779:2002 for fresh and exhausted air. As an option it is possible to produce the unit with filter class F7, which leads to reduction of the external pressure of the unit.



Water heat exchanger - heating and cooling: Three-way valve is used to manage the unit. An installation of additional water pump is required.



Electric heater: The capacity of the electric heater is automatically controled until the selected temperature of supply air is achieved.



On request units could be produced with centrifugal backward wheel fans with high efficient EC motors. Thus the energy consumption is less. The fans are 0-10V controllable.



Air duct system

Made of round or rectangular air ducts, sized according to the air volume, necessary for room ventilation. The ducts shall be thermally insulated.



Heat recovery unit

Heat recovery unit EVB AL/AL+ with efficiency up to 65%.



Supply and suction ventilation grilles

Ensure supply and suction of air into the room.





Rev.02/2014



© 2014 TANGRA

Headquarter

Sofia, 174, Europe boulevard

Phone: +359 2 925 05 99; +359 2 925 06 10

www.tangra.bg

Varna, West Industrial Zone INCOVES

Phone: +359 52 611 767

Burgas, 6, Transportna Street

Phone: +359 56 86 12 00